



Guide to the Application & Troubleshooting of Electrostatic Coatings

TCI Powder Coatings

Guide to the Application & Troubleshooting of Electrostatic Coatings

Chapter One	
Early Powder Coatings, Uses and Types.....	3
Chapter Two	
Manufacturing of Powder Coatings.....	4
Chapter Three	
Powder Chemistries, Formulations, Comparisons, and Uses.....	6
Chapter Four	
Comparisons to Liquid Coatings.....	8
Chapter Five	
Measuring Up the Product.....	9
Chapter Six	
Pretreatment.....	10
Chapter Seven	
Powder Application Methods and Equipment.....	12
Chapter Eight	
Powder Coating Recovery Equipment.....	15
Chapter Nine	
The Electrostatic Charge Process.....	17
Chapter Ten	
Powder Application Tips.....	22
Chapter Eleven	
Powder Curing Process.....	28
Chapter Twelve	
Safety Issues with Powder Coatings.....	33
Chapter Thirteen	
TCI Troubleshooting Guide.....	37
Glossary of Related Terms.....	46

Chapter One

Early Powder Coatings, Uses and Types

- ⇒ Porcelain and other vitreous enamels are among the earliest of dry coatings and began appearing around 1000 B.C.
- ⇒ Porcelain was used extensively on cast iron starting in the mid 19th century
- ⇒ By the 1950's the first organic coating, thermoplastic vinyl, was being applied with a fluidized bed
- ⇒ In France the first commercial applications of epoxies began in 1962
- ⇒ Spray application appears in Europe in 1968
- ⇒ European technologies appear in the U.S in 1972
- ⇒ By the early 1980's smoother and thinner film coatings add economic advantages leading to a dramatic growth in the use of electrostatic coatings

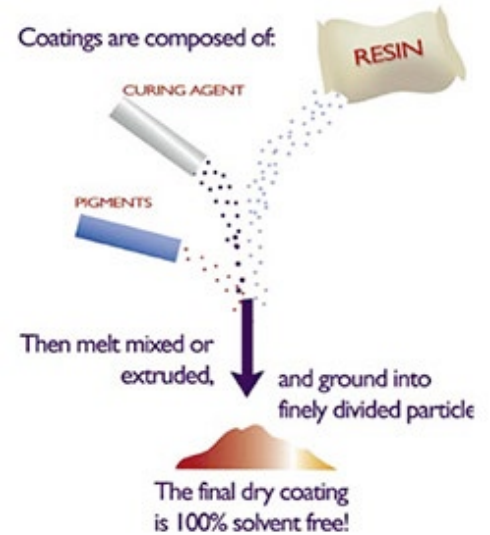

WHERE POWDERS ARE USED

Around the Kitchen:

Washer/dryer shells and motor castings; refrigerators, refrigerator shelving and motor casings, faucets, sinks and small appliances

Outside the House:

Lawn and garden tools, mowers, edgers and patio furniture

In the Workplace:

Computer hardware, office furniture, filing cabinets, storage and display shelves, warehouse racks, lighting fixtures

Heavy Equipment:

Agricultural mowers, irrigation equipment, tillers and construction earth moving equipment

Building Products:

Rebar and steel cable, columns, water treatment facilities, HVAC units, gas and oil transmission lines, windows, sliding doors, canopies and architectural decoration

Transportation Equipment:

Truck and trailer wheels, mirrors, supports, frames, steering wheels, wipers, springs, shocks and other miscellaneous auto parts



Chapter Two

Manufacturing of Powder Coatings

Weigh-up & Mixing

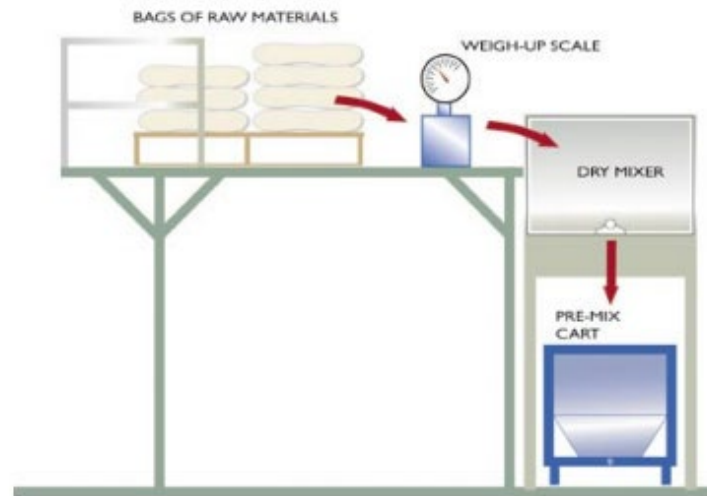

Extrusion Process

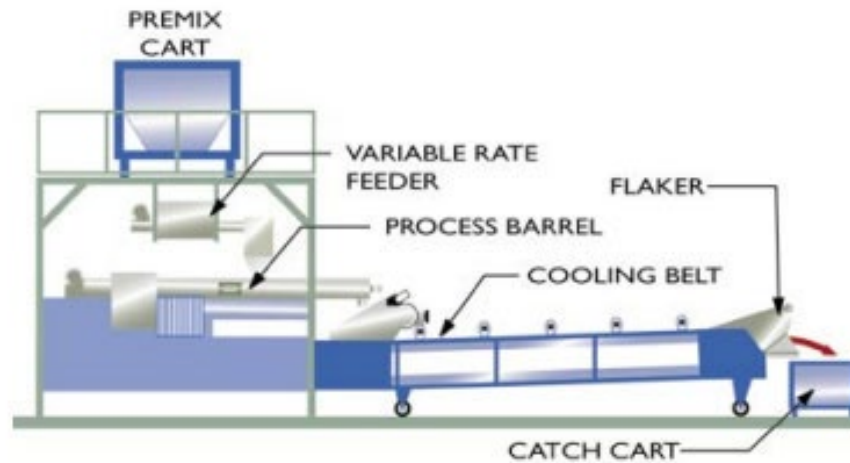

Milling & Sieving

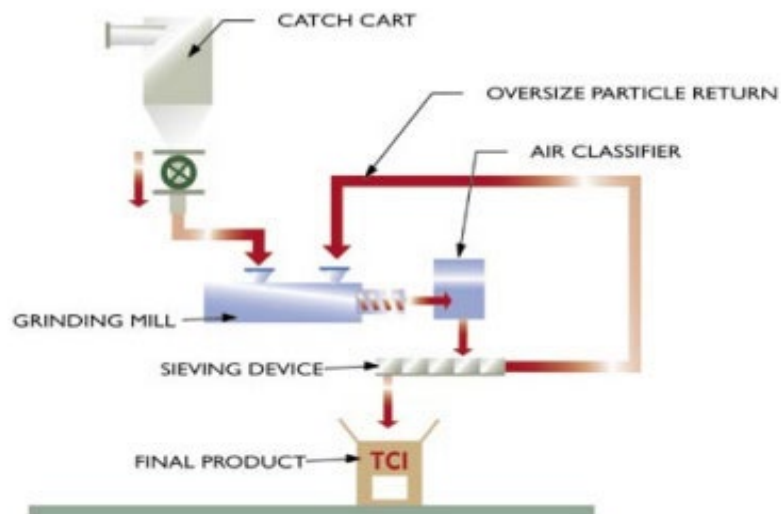

Particle Size Distribution

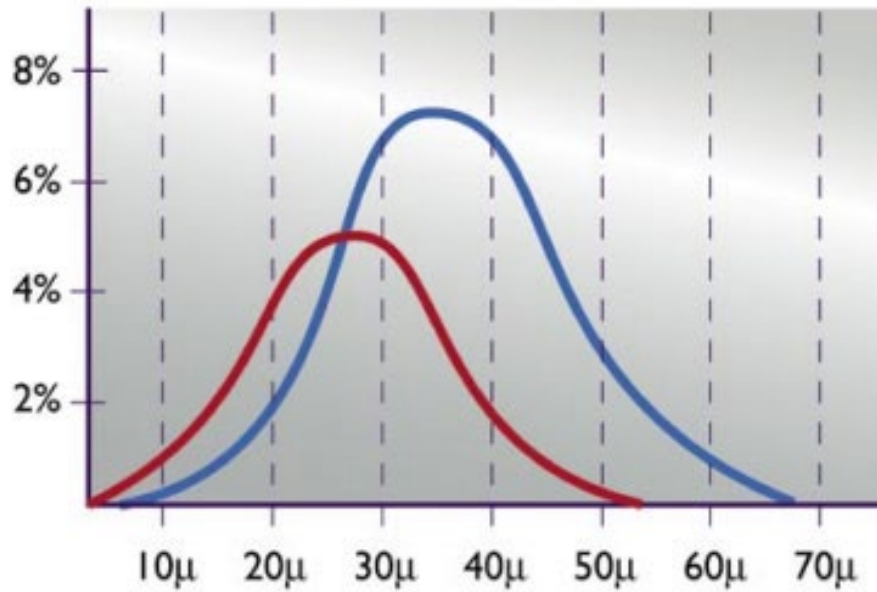

Typical Medium Grind Distribution

Virgin Powder 28-34μ Mean

Virgin Powder with Reclaimed Powder 20-24μ Mean

EFFECTS OF PARTICLE SIZE

Fine Particles:

- Have lower film builds
- Can blind cartridges and filters
- Migrate from part into exhaust
- Reduce fluidization properties
- Reduce Faraday penetration
- Result in smoother films
- Absorb moisture more readily

Coarser Particles:

- Have higher film builds
- Increase Faraday penetration
- Increase fluidization properties

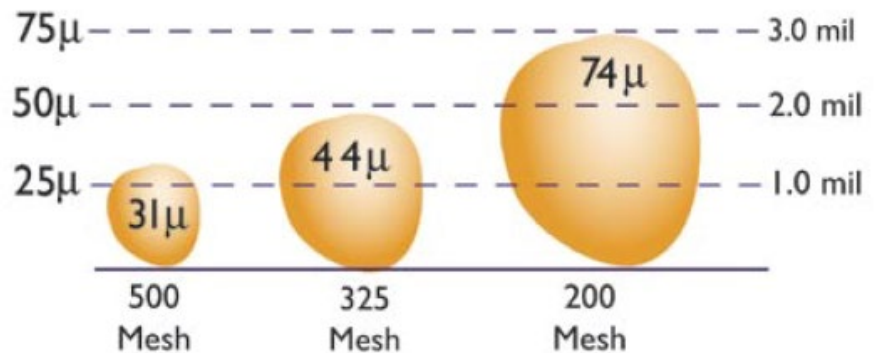

Chapter Three

Powder Chemistries, Formulation, Comparisons and Uses



1000 Series Low Cure Systems are formulated for heat sensitive substrates. Products are typically formulated to cure at 250°F. Lower temperatures are possible. Power can be applied with or without minimal substrate preheating. Products in this series will rapidly lose gloss and chalk on exterior exposure and are best suited for interior application. These products feature excellent physical and chemical resistance properties. Typical uses include medium density fiberboard (MDF), fiber reinforced plastic (FRP), and sheet molding compounds (SMC). Each customer's substrate and application technology must be evaluated before ordering powder.

2000 Series Acrylic Systems have a broad formulating range and can meet many decorative application requirements. Products in this series can have increased hardness, chemical resistance, overbake resistance, and weatherability when compared to standard systems. Products can be formulated for interior and exterior applications. Contact a TCI sales representative or TCI chemist to determine suitability of this technology.

3000 Series High Temperature Systems are formulated to provide coating stability in elevated temperature applications. Products can be formulated for different levels of continuous or intermittent temperature exposure. Contact a TCI chemist to initiate a product design for high temperature applications.

4000 Series Specialty Systems have a broad formulating range and are utilized to meet unusually demanding requirements of decorative and functional applications. This series is recommended when conventional formulas will not meet a customer's performance specifications. Contact a TCI chemist to initiate a product design for demanding applications.

5000 Series Alternative Cure Polyester Systems can provide solutions where TGIC or urethane polyesters are not approved. Products in this series can be formulated to meet many decorative requirements for gloss, smoothness, color, and weatherability. Typical uses include interior and exterior furniture, sports equipment, and machinery.



6000 Series Epoxy/Polyester Hybrid Systems have a broad formulating range and can meet many decorative and functional application requirements. Products in this series will rapidly lose gloss and chalk when exposed to sunlight and are best suited for interior applications. This series has a good balance of physical properties and excellent application characteristics. Typical uses include automotive accessories, exercise equipment, power tools, and display racks.

7000 Series Epoxy Systems have a broad formulating range and can meet many decorative and functional application requirements. Products in this series will rapidly lose gloss and chalk when exposed to sunlight and are best suited for interior applications. Epoxy systems can be formulated to have excellent chemical resistance and physical properties. Typical uses include automotive underbody, corrosion resistant primers, and material handling components.

9000 Series TGIC Polyester Systems have a broad formulating range and can meet many decorative and functional requirements for gloss, physical properties, chemical resistance, color, and weatherability. Products in this series can be used in thick film applications. Typical uses include aluminum extrusions, playground equipment, agricultural equipment, and machinery.

10000 Series Superior Exterior Performance TGIC Polyester Systems are formulated to meet the requirements of the AAMA 2604 specification. Products in this series have a 60° gloss range of 5-90°+ and are available in a wide selection of colors. Proper chrome or non-chrome pretreatment is critical for product performance. A TCI technical representative must audit each application system to ensure products will meet the 2604 specification.

11000 Series Highest Exterior Performance Organic Systems are formulated to meet the requirements of the AAMA 2605 specification. Products in this series, with the exception of anodized products, have a 60° gloss range of 25-70°+ and are available in many colors. Proper amorphous chromium phosphate or amorphous chromate pretreatment is critical for product performance. Alternative chrome and/or non-chrome conversion coatings should be maintained according to supplier's recommendations. A TCI technical representative must audit each application system to ensure products will meet the 2605 specification.



PROPERTY COMPARISONS

Property	1000	2000	3000	4000	5000	6000	7000	8000	9000	10000	11000
Hardness	E	E	G	VG-E	VG	VG	E	G	VG	VG	VG
Flexibility	E	P	G	VG	E	E	E	E	E	E	E
Overbake Stability	P	E	E	VG	E	VG	P	G	E	VG	VG
Exterior Durability	P-E	P-E	P-E	P-E	E	P	P	E	E	S	HP
Corrosion Protection	E	VG	G	E	VG	VG	E	VG	E	E	E
Chemical Resistance	E	E	G	VG	VG	VG	E	G	VG	VG	VG
Application Properties	VG	G	G	VG	E	E	E	G	E	VG	VG

P=Poor G=Good VG=Very Good E=Excellent S=Superior (AAMA 2605) HP= Highest Performance (AAMA 2605)

Interior Applications- 1000, 2000, 3000, 4000, 6000, 7000

Exteriors Applications- 2000, 3000, 4000, 5000, 8000, 9000, 10000, 11000

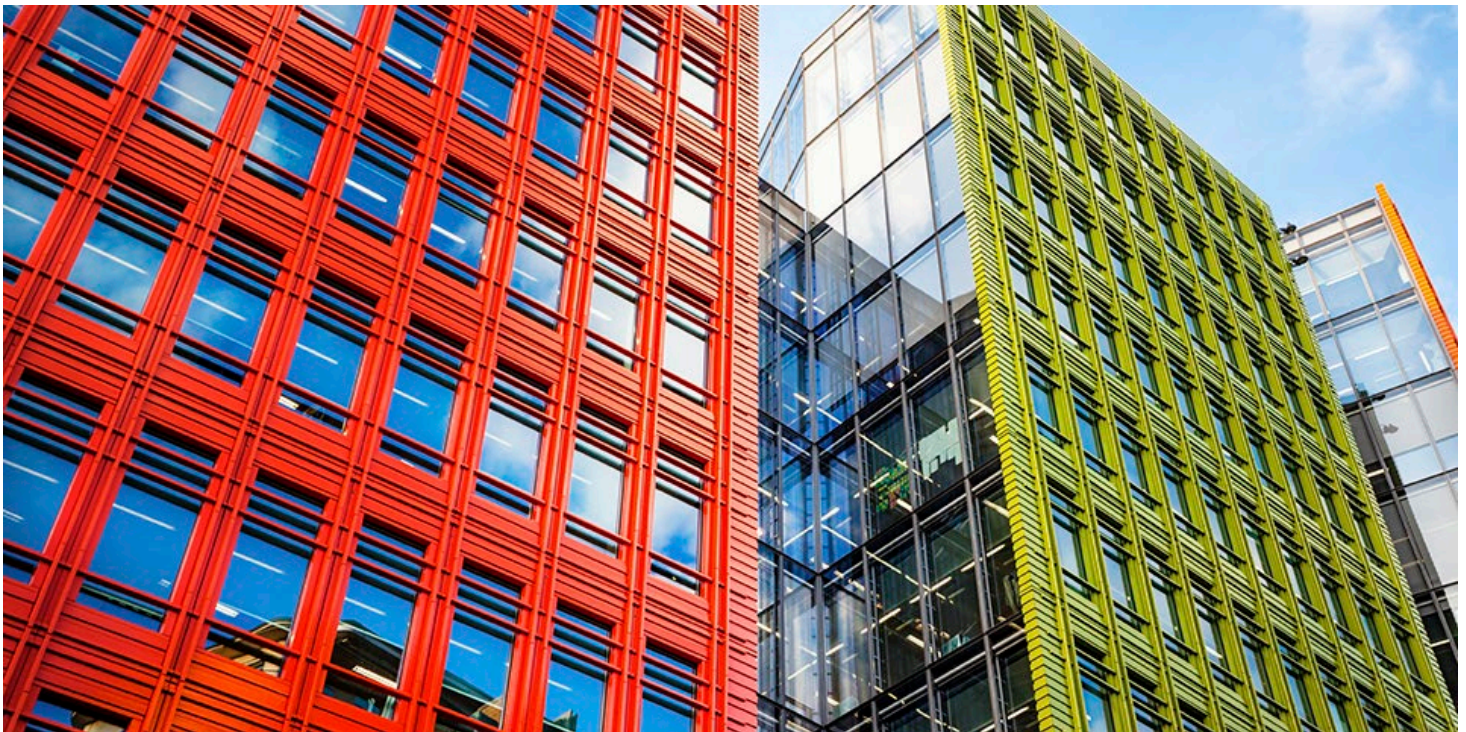

Notes: 1)- Square foot coverage/lb./mil 2)- 2 mil coating bent over 1/8” mandrel 3)-1/8” cross-hatched squares * 102ft² /#/mil-160ft² /#/mil @ 1.2-1.9 SG ** These are maximum values; many formulas will not have maximum values. *** ASTM D- 1654: ≥ procedure A; ≥ procedure B. **** ASTM D= 1654 ≥ procedure B

Chapter Four

Comparisons to Liquid Coatings

- ⇒ Powder coatings have been used more and more since the 1970's and for many reasons including environmental, performance, productivity and economics. Powder coatings are clean, producing almost no VOC's. In addition, they provide easy clean up with no harmful solvents and produce no harmful waste.
- ⇒ Most overspray can be reclaimed and recycled for greater economic savings over liquids. Much of the application is automated reducing the cost of labor to coat products.
- ⇒ Powder coatings cannot be modified at the customer site, thereby eliminating product inconsistency.
- ⇒ While powders cure at a higher temperature than liquids they cure more rapidly saving time and energy. As with most coating systems preparation is key, and powders are no exception. Presently many cured powder coatings can provide superior finishes to properly pre-treated products verse their liquid counterparts.

ADVANTAGES OF USING POWDER COATINGS

Environmental:

- Near 0 VOC's
- No sludge or solvent disposal
- Virtually 100% efficient in material use
- Reduced health, fire, and safety hazards

Performance and Quality:

- Tougher, more durable coatings
- More impervious and corrosion resistant
- More consistent finishes

Productivity:

- Ease of application
- Fewer rejected parts
- Reduced cleanup
- Fast turnaround

Economics:

- Lower disposal costs
- Lower energy costs
- Lower labor costs
- Lower reject costs
- Lower applied materials cost



Chapter Five

Measuring Up the Product

CALCULATING SPECIFIC GRAVITY AND WHY IT AFFECTS COVERAGE

- Calculating the Coverage at 100% Efficiency:

$$\frac{192.4}{(\text{Specific Gravity}) \times (\text{Mils})} = \text{ft}^2/\text{lb}$$

- Calculating the Applied Cost at 100% Efficiency:

$$\frac{\text{Area to be Covered}}{\text{Coverage ft}^2/\text{lb.}} = \# \text{ lbs to Cover}$$

$$\# \text{ lbs} \times \$/\text{lb} = \text{Cost}$$

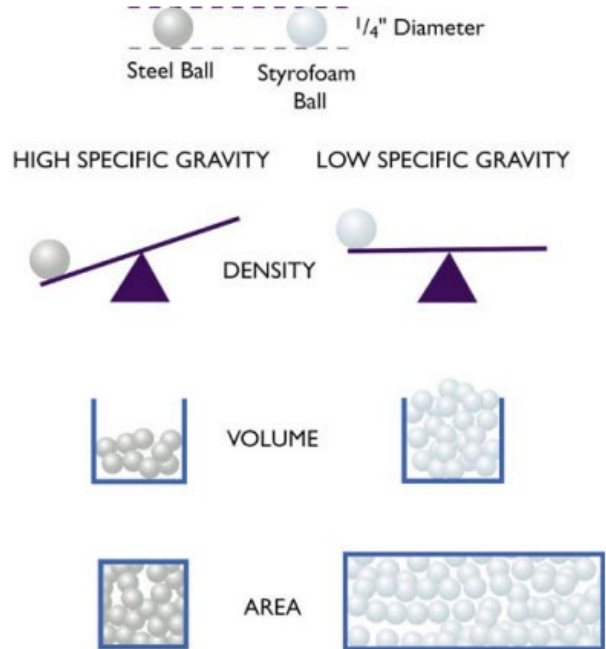

COVERAGE EXAMPLE:

ABC Fabrication is getting a price on coating 120,000 sq. ft. of sheet metal from two different companies using a film thickness of 2.25 mils.

Company X is asking \$2.28 per pound, and Company Z is asking \$2.58 per pound. At 30¢ less per pound Company X is 12% lower and appears to have the better price. But look closer.

Company X's price is \$2.28/lb. and SG =1.68

Company Z's price is \$2.58/lb. and SG =1.28

$$\frac{192.4}{(1.68) \times (2.25)} = 50.90 \text{ ft}^2/\text{lb}$$

$$\frac{192.4}{(1.27) \times (2.25)} = 67.33 \text{ ft}^2/\text{lb}$$

$$\frac{120,000}{50.90 \text{ ft}^2/\text{lb.}} = 2,358 \#$$

$$\frac{120,000}{67.33 \text{ ft}^2/\text{lb.}} = 1,782 \#$$

$$2,358 \times \$2.28 = \$5,376$$

$$1,782 \times \$2.58 = \$4,598$$

So, the real savings is with Company Z, \$778 in material costs. It continues to add up, 576 fewer pounds of powder means less freight costs. And since there is less powder there is less time and wear on the spraying machines. Specific gravity is an important factor in determining coverage and cost per square foot.

Though powder is purchased by the pound it is applied by volume. Therefore, purchasing powders with a lower weight per volume will coat more square footage of substrate

Chapter Six

Pretreatment

Perhaps one of the most important steps in powder coating is pretreatment. Pretreatment allows for the proper adhesion of the powder to the substrate and ensures the long-term adhesion of the coating to provide lasting resistance to corrosion. The process requires three steps.

1) Cleaning- Removes soils, oils, oxides, smut and contaminants

- ⇒ Factors to consider include accurate levels to improve soil removal, decrease the cleaning time and provide an optimum surface for the phosphate layer. Titration readings measure the total alkalinity or acidity levels.
- ⇒ Increased temperatures will improve the action of the detergent and allow for less time in the cleaning process.
- ⇒ Be careful to watch for sludge or soil build up in tanks that will reduce the cleaning activity even with good titration readings.

2) Rinse- Removes any remaining contaminated solutions from the surface while diluting the chemicals to stop their action. It also adjusts the pH for the next step

Chemical Conversion of the Surface
Common Types Include:

- Zirconium pretreatment for steel, galvanized and aluminum substrates
- Iron phosphate for ferrous metals
- Zinc phosphate for ferrous metals
- Chromate conversion for aluminum
- Manganese phosphate

- ⇒ Conversion coatings are a complete film which changes the physical and chemical nature of the metal surface. These coatings deposition weights are measured in milligrams and are grey to blue iridescence or blue to gold iridescence. A clean surface is required for the reaction.

3) Seal- Neutralizer stabilizes the conversion coating

- ⇒ The temperature of the rinse increases the solubility of the residues and improves dry off time. Proper flow patterns and rinse volume promote a more thorough rinse.
- ⇒ Overflows and screens are used for the removal of the soils, oils, and other contaminants.

Remember to WATCH:

Water Action Time Chemicals Heat

PHOSPHATE COMPARISONS

	Iron Phosphate	Zinc Phosphate
pH	4.5-5.5	1.5-3.5
Composition	Iron phosphates Iron oxides	Phosphates of Zn, Fe, Mn, Ni
Coating Weight	20-80 mg/ft ²	100-350 mg/ft ²
Sludge	Minimal	Low-High
Accelerators	Inc. coating weight	Dec. coating weight
Adhesion: Forming Type Scrape Type	Excellent Fair to good	Poor to good Good to excellent

CROSS SECTION OF PHOSPHATED AND COATED STEEL



PHOSPHATE CONTROL FACTORS

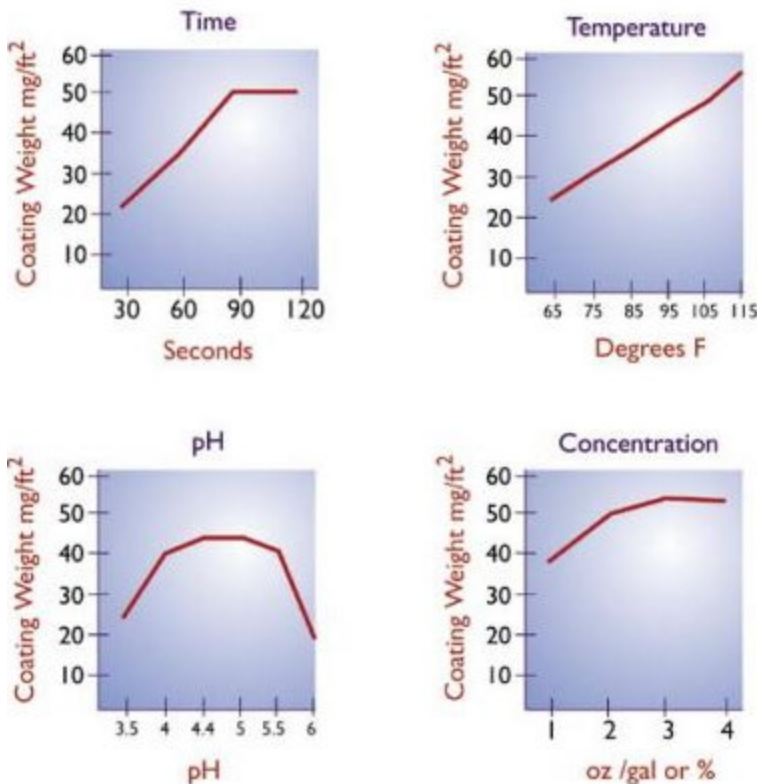

MECHANISM OF PHOSPHATING

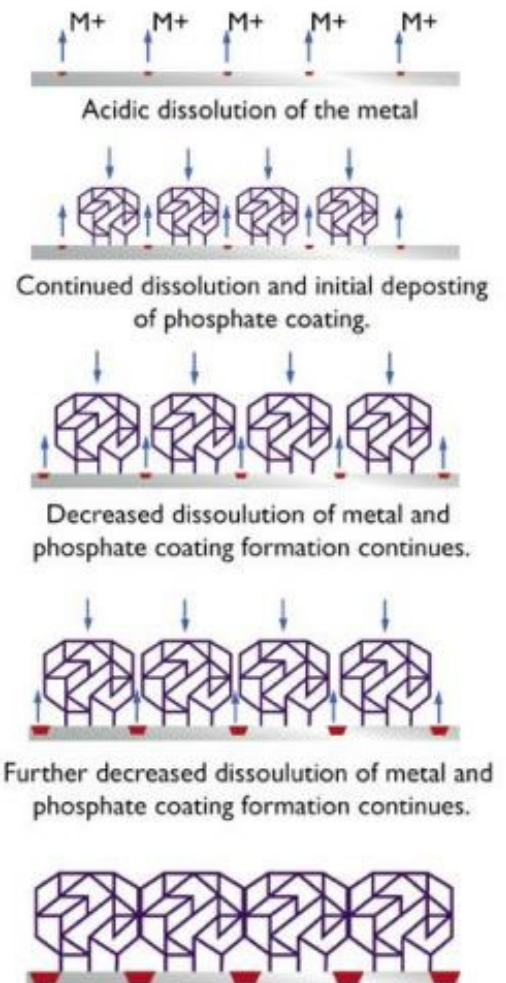

Chapter Seven

Powder Application Methods and Equipment

The method chosen to apply powder coatings is varied depending upon the specific part. Fortunately, powder coating technology offers many choices in the application process.

Factors to Consider in Coating Methods

- Film thickness requirements
- Line speed
- Part configuration/size/thickness
- Powder coating chemistry
- Product performance characteristics

Application Methods Available

- Fluidized bed
- Electrostatic fluidized bed
- Electrostatic (Corona) spray
- Triboelectric/Tribostatic spray
- Other various methods
Including: flocking, electrostatic disc, tunnel coater, flame spray, plasma spray, electromagnetic brush

FLUIDIZED BED COATING

The fluidized bed process is used for coatings between 10 -15 mils with the final thickness dependent upon part temperature and dip time in the powder. The film can be applied in thickness from 8-125 mils. This process requires pre-heat temperatures of at least 350°F and may require a post-heat or cure cycle.

Typical Uses: buss bars, transformers, fabricated wire, metal furniture, raceways

Advantages:

- Uniform coating
- Product reliability
- Thick coatings
- Complex parts 100% coverage
- Good edge coverage
- Good process control

Disadvantages:

- Pre-heat & post-heat ovens required
- Larger heavy parts must be manipulated into bed
- Thinner substrates do not hold heat, difficult to coat
- Complex shapes trap excess powder
- Minimum of 8 mils to be applied

Steps:

- 1) Part pre-heated to 400-450°F
- 2) Initial deposit melts onto part
- 3) Film builds from residual heat
- 4) Coated part with desired film

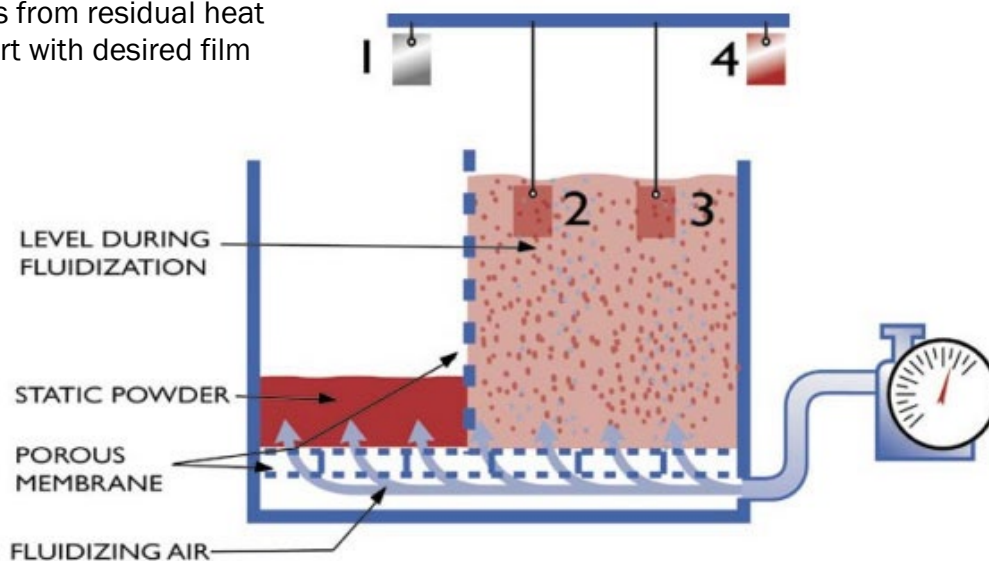

FLUIDIZED BED COATING

Electrostatic fluidized beds are especially applicable to continuous coating of sheet, wire screen and small simple configuration parts. The effective coating range is only 3-4 inches over the bed and will not coat parts with deep recesses. Coatings range from 0.8 to 3 mils on relatively high-speed lines.

Advantages:

- High-speed lines
- Easily automated
- Thin films possible
- Acceptable to continuous length products

Disadvantages:

- Coating area limited to 3-4 inches above bed
- Restricted product flexibility
- Best for 2 dimensional parts

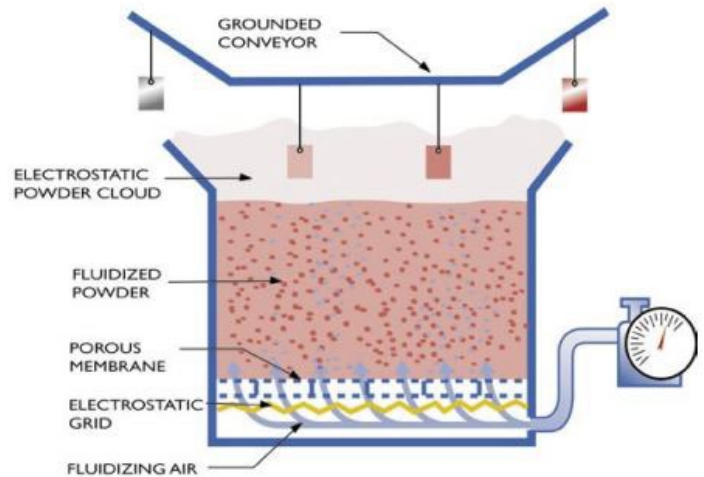

ELECTROSTATIC SPRAY (CORONA CHARGING)

Corona charging is the most common method used in powder. The process disperses finely ground powder into an airstream, producing a cloud as it exits the gun. The particles pass through a highly charged and ionized corona field at the gun tip applying a strong negative charge to each particle. These particles have a strong attraction to the grounded part and deposit there. This process can apply coatings between 0.8 and 10 mils in thickness. Corona charging can be used for decorative as well as functional coatings. Virtually all resins with the exception of nylon can be applied easily with this process. Making color changes in this type of system varies. Most handgun operators can change over box units in less than 10 minutes. Hopper changes can be as little as 20 minutes if using the same hopper. Color change times for standard systems average between 45-60 minutes.

Advantages:

- Heavy films
- High transfer efficiency
- Only one oven, spray parts cold
- Applies quickly
- Can be automated
- Minimum operator training
- Works with most chemistries

Disadvantages:

- Difficult color changes in automatic systems comparable to Tribo systems
- Requires high voltage source
- Some difficulty with deep recesses
- Thickness control sometimes difficult
- Capital cost higher than other application methods

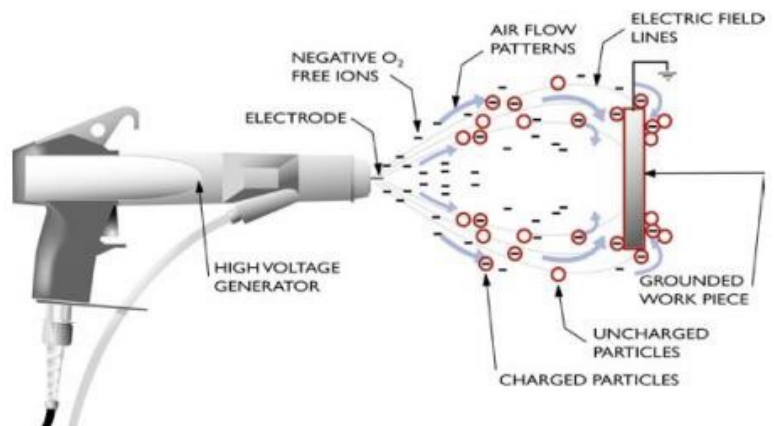

ELECTROSTATIC SPRAY (TRIBOMATIC STATIC CHARGING)

Tribomatic static charging is the second most common method of spraying a powder coating. This method relies on the powder to develop a charge while passing through special hoses and guns. As powder contacts these non-conductive surfaces, electrons are stripped off of the particles due to friction. These particles then develop a powerful positive charge. No high voltage or lines of force are used which allows for easier penetration into deep recesses. Tribomatic charging is efficient in developing a static charge within the powder, however, coatings must be specifically formulated for this system.

Advantages:

- No high voltage source required
- Better penetration into recessed areas
- Slightly lower capital cost

Disadvantages:

- Level of charge varies with powder chemistry and formula
- Slower rate of application
- Transfer efficiency is lower than corona charging system
- Requires more guns
- Wears out parts faster

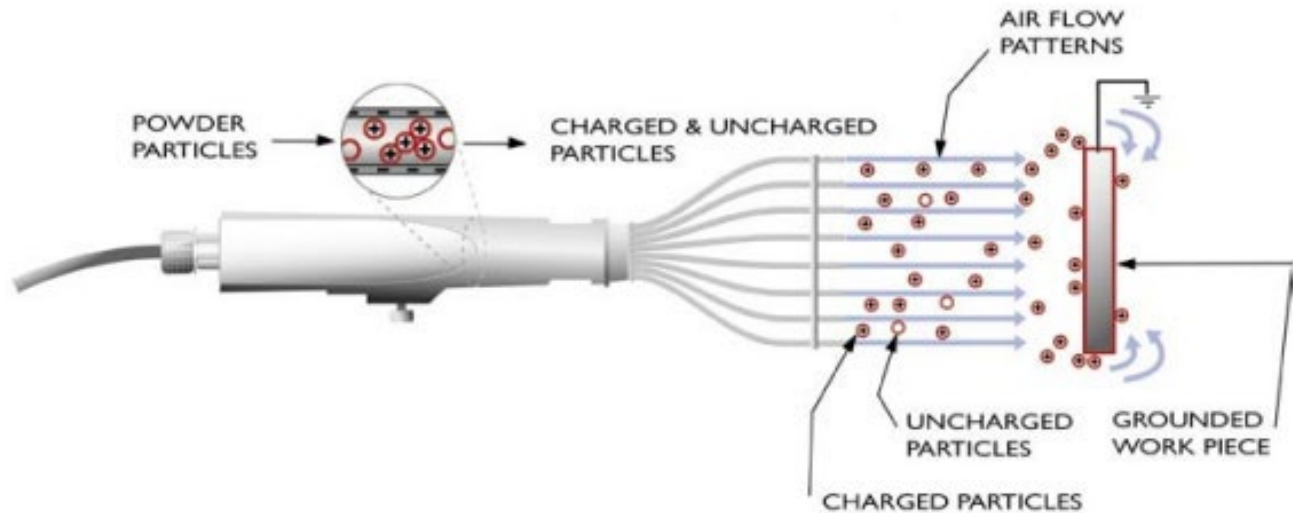

COMPARING CORONA CHARGING TO TRIBOMATIC SYSTEMS

Critical Variables	Corona	Tribomatic
Faraday Cage	More difficult to coat recesses	Easier to apply to recesses
Back Ionization	Easier to coat thinner films	Easier to produce thicker films
Product Configuration	Not good for complex shapes	Very good for complex shapes
Production Requirements	Wide range of line speeds	Good for lower line speeds
Powder Chemistry	Less dependent on chemistry	More dependent on chemistry

Chapter Eight

Powder Coating Recovery Equipment

GENERAL DESIGN PRINCIPLES

Powder coatings are efficient in their use partly due to the ability to recover and reuse the excess overspray from the coating booths. The recovery system consists of three components, the booth which contains the excess powder, the collector which retrieves the excess, and the filters which clean and return the air.

Booth

- Allows for a contained area for the application and containment of excess powder
- Provides a controlled atmosphere with safe operating levels of powder cloud density
- Permits the maximum possible exposure time of the parts to the powder cloud
- Optimize the powders cloud concentration towards the parts and away from the booth walls

Collector

- Separates the powder from the air stream exhaust
- Allows for a maximum retrieval rate of over sprayed powder
- Permits a central collection area to reintroduce reclaim powder into the virgin powder

Filter

- Allows for the return of cleaned conditioned air, either heated or cooled, back into the coating area

CONVENTIONAL RECOVERY SYSTEM (CYCLONIC)

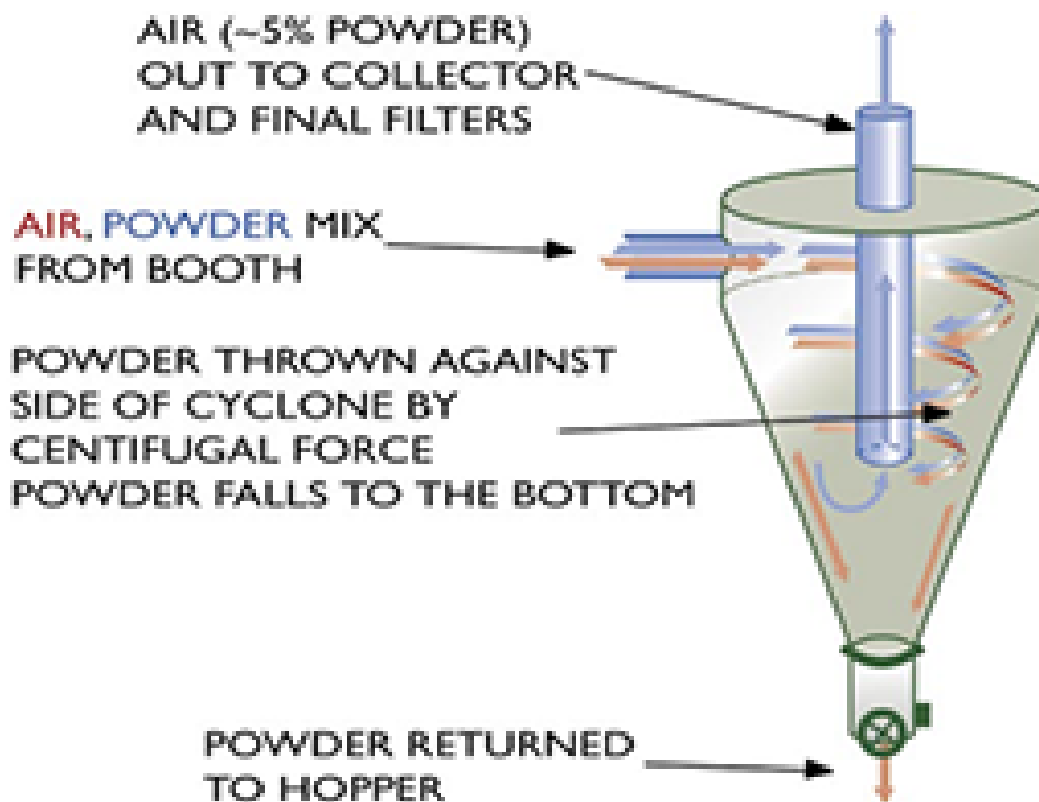

CARTRIDGE RECOVERY SYSTEM

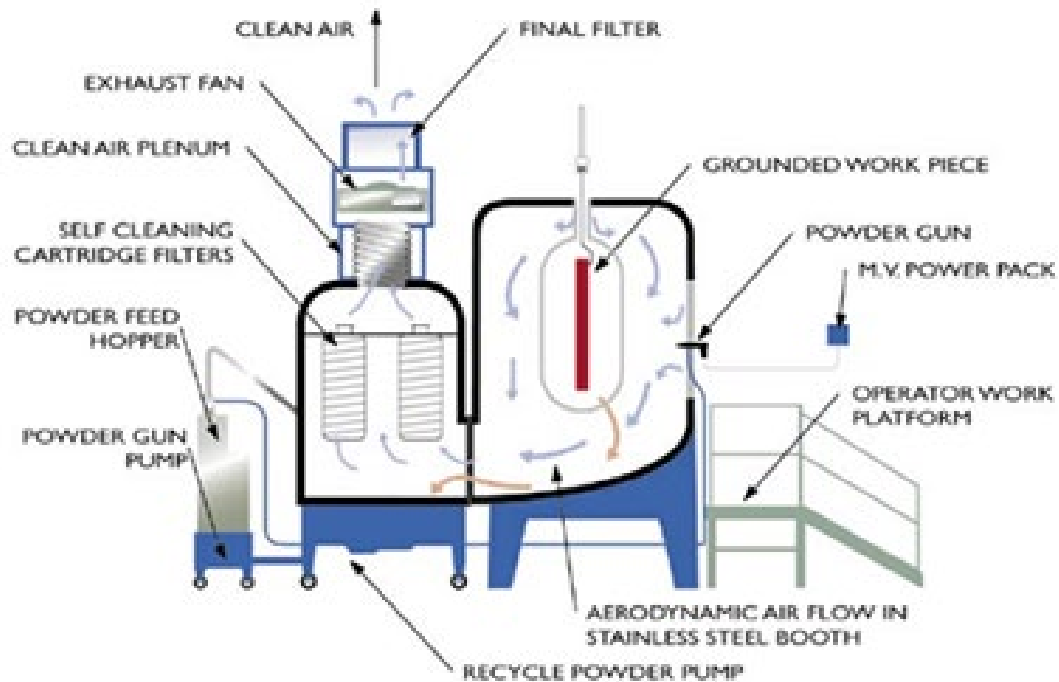

Daily Booth Maintenance

- Cartridge, final filter, or baghouse magnehelic pressures should be checked daily
- Collector filters and final filters should be changed when magnehelics reach preset numbers
- Guns, pumps, and hoses should be inspected for wear, holes and impact fusion
- Voltage and current of guns and power source must be checked monthly to insure maximum charge
- Booth should be cleaned at least twice a day to keep reclaim powder mix to a minimum
- Preferably 4 times a day or every two hours. This will reduce the exposure of the powder to moisture and “trash”
- UV detectors must be checked and cleaned daily to insure they are working correctly
- Always stay alert for signs of moisture or oil on any of the system components. Perform maintenance immediately if any is found
- Keep records of all the checks done and maintenance performed to the finishing system and line

Color Change Considerations

- Guns should be disassembled and blown out with compressed air
- Powder feed hoses should be blown out or with extreme color changes they should be replaced with dedicated hoses
- Pumps, injector blocks, venturis, should be disassembled, inspected for wear, then cleaned with compressed air
- Booth floor, walls and ceiling should be cleaned with a squeegee, while the recovery system is running
- Sieve, virgin and reclaim feed hoses and collector cyclone should be thoroughly cleaned.
- Powder hoppers should be cleaned thoroughly or replaced with dedicated color hoppers
- All areas which will be in contact with the powder must be wiped or vacuumed clean, including the inside of the booth and hoppers
- Multiple booths with roll on/off tracks will allow one booth to be cleaned while another is coating. This will reduce downtime as well as the risk of contamination
- Additional dedicated color cartridge units, hoppers and sieves will also significantly speed up color change times

Chapter Nine

The Electrostatic Charge Process

CORONA CHARGING

- Typical voltages of 40,000 to 100,000 VDC
- Typical currents of 15-60 Micro amps
 - One milliamp is 1/1,000th of an amp and would cause a small but noticeable shock
 - One micro amp is 1/1,000,000th of an amp and would cause no sensation at all
 - • 15-60 micro amps will not harm humans though extended exposure might cause tickling sensation-similar to a carpet shock
- Symbol for Micro amp is: μA

CORONA CHARGED ELECTRIC FIELD LINES

- The corona field creates field lines of force coming out of the gun which converge on sharp edges and points
- Free electrons follow the lines of force
- The electrons hit air molecules splitting them into 2 more electrons and 1 ion
- New electrons hit new air molecules
- Free ions travel towards the source
- Ions also hit and split air molecules

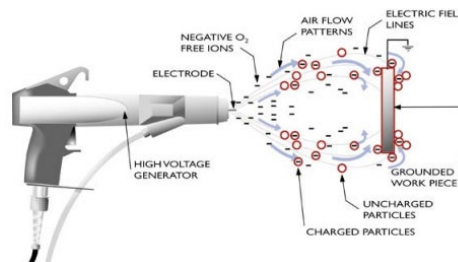

CORONA CHARGING OF POWDER PARTICLES

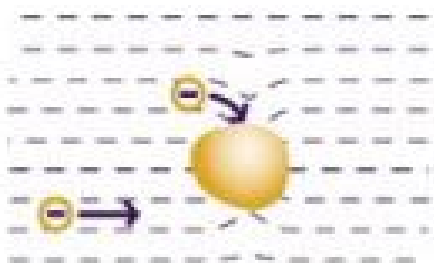

- The uncharged powder particle will attract field lines
- Free ions will begin to be captured by the particle
- The particle continues absorption until it has the same potential as the incoming ions
- Degree of charge absorbed depends on particle size, field strength, and time in charge area

CORONA CHARGING PARTICLE SATURATION

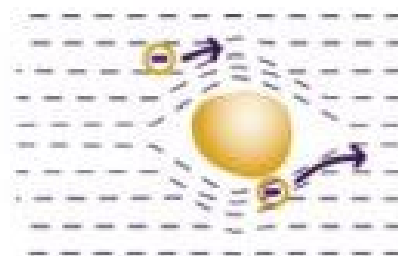

- When the particle has reached its saturation point of captured ions it develops its own electric field
- This new field will then cause lines of force to be pushed away from the particle
- Ions can no longer reach the particle due to repulsion

Several forces act on the moving particle to deliver and deposit it on the part: air resistance, aerodynamic force, electric force, and gravity. Importantly electric force can only complete its function if the product substrate is properly grounded.

ELECTROSTATIC ATTRACTION

Electrostatic Attraction of Powder at The Substrate Surface

- Powder will retain a charge for several hours (minimally) if grounded properly
- As a powder contacts a grounded surface it induces an equal and opposite charge on the surface of the substrate
- This occurs because like ions are repelled from the area
- This reaction is called a “mirror” charge and serves to hold the powder particle in place
- The larger a particle (retained charge) the stronger the charge and attraction

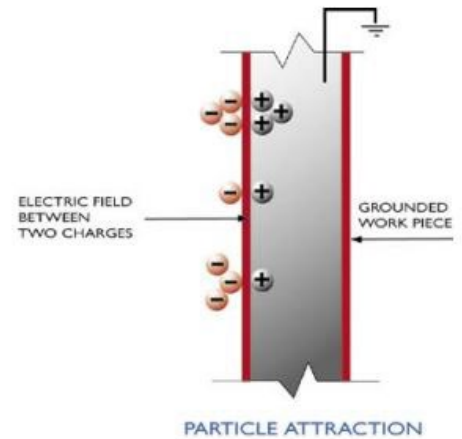

Electric Deposition of The Powder

- Large particles typically accumulate stronger charges. Therefore, larger particles will tend to build on top of smaller particles deposited more directly on the surface

Back Ionization and What Causes It

Back ionization is caused primarily when the part has reached the saturation point at which no additional powder can be attracted to the substrate. Indications may be:

- Limited film build
- Powder attracted to the applicator, not the part
- Star/swirl patterns

As powder continues to be deposited on the part the strength of the electric field within the powder layers increases because each new particle:

- Increases cumulative charge of the film
- Increases the cumulative mirror image

If spraying continues beyond the saturation point the electric field within the film will become high enough to:

- Inhibit deposits of additional particles
- Ionize trapped air within deposited particles
- Split more air molecules with new +/- ions
- Cause electron streams to rush through the coating towards the ground repelling charged particles
- Cause ion streams to rush through the coating toward the gun, the canceling charge of particles
- Cause these streams to disrupt deposited powder film ripping powder away and creating voids and craters, or star patterns, in their wake

Adjustments for back ionization include:

- Checking the ground and hook cleanliness
- Increasing gun to part distance
- Decrease voltage by 10-20Kv
- Insure reclaim to virgin mix is correct

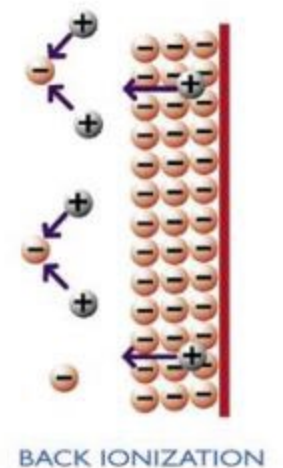
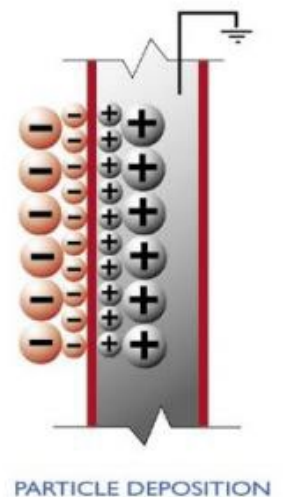

CONVENTIONAL ELECTROSTATIC UNITS

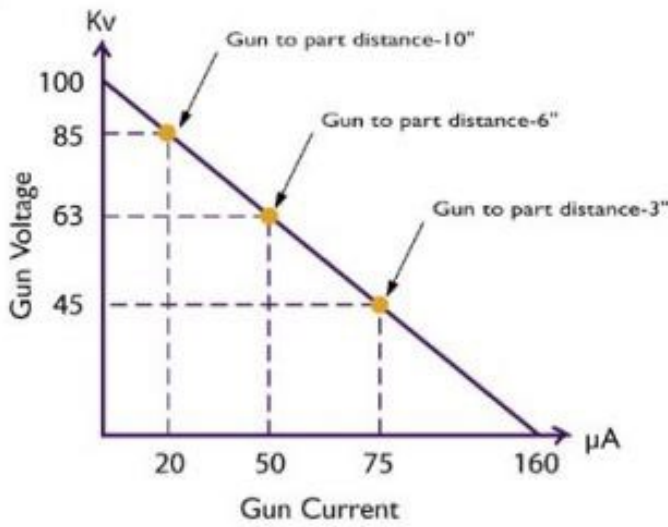

Current Output

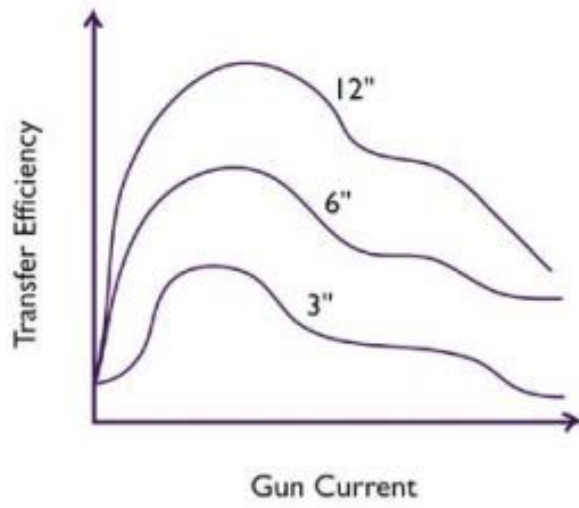

Transfer Efficiency vs. Gun to Part Distance

FARADAY CAGE EFFECT BASICS

Attractive forces are inversely proportional to the square of the target distance

$$Force = \frac{1}{(Distance)^2}$$

Current Output

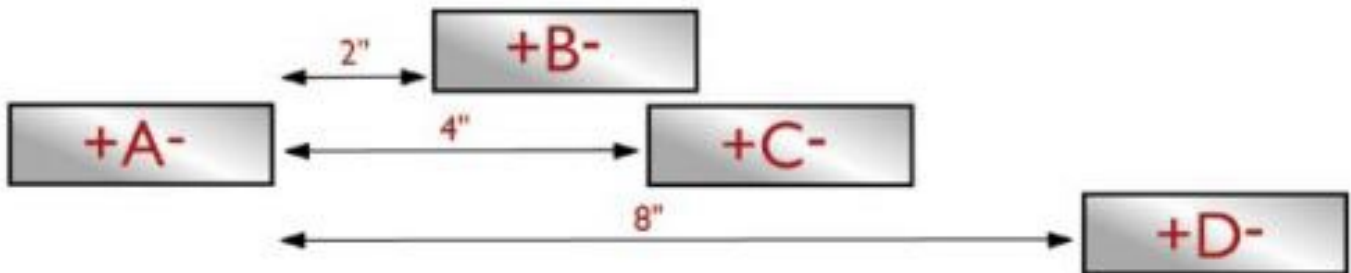

- A to B = 2" (1/(2x2) = 0.25 or relative force= 16
- A to C = 4" (1/(4x4) = 0.0625 or relative force= 4
- A to D = 8" (1/(8x8) = 0.0156 or relative force =1

FARADAY CAGE EFFECT BASICS CONTINUED

Contributing Factors

- Edges build quickly, and can back-ionize before recesses and other areas can coat as in the figure at right
- Corona charging creates strong electric fields
- Edges offer the least amount of resistivity
- Electric fields follow paths of least resistance
- Charged particles follow with lines of force
- The less the distance the more the attraction
- When coating recesses the amount of powder deposited is also limited by the extra surface area to be covered

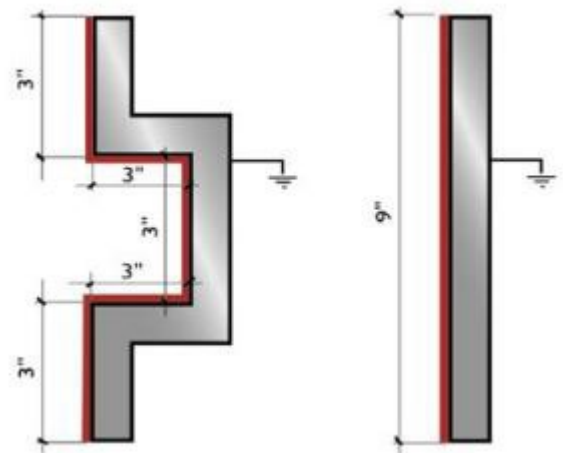
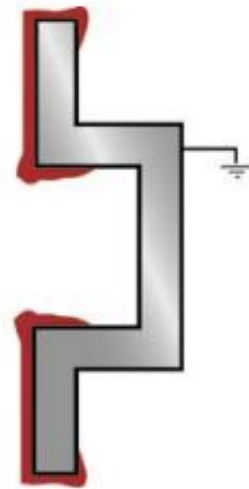

- A- The Space Charge
Consists of charged particles and free ions which also creates its own electric field toward the part
- B-Lines of Force
Corona generated charge field and lines of force from the electrode

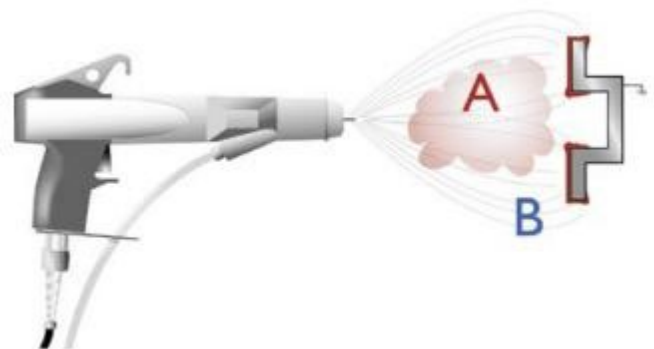

FARADAY CAGE EFFECT BASICS CONTINUED

Effect of Particle Size on Surface Area and Charge

The charge developed by a powder particle is a function of the charge to mass ratio. This ratio is inversely proportional to the radius of a particle. Larger particles charge less efficiently. A (one) 1 mil particle has 1/512th the mass of an 8-mil particle, but the total volume of smaller particles making up that mass will carry 8 times the charge due to the increased surface area.

Base Size	Number of Particles	Surface Area
8 Mils	1 Particle	1 Unit
4 Mils	8 Particles	2 Units
2 Mils	64 Particles	4 Units
1 Mil	512 Particles	8 Units

Current Limiting Devices

Current limiting devices were developed to help minimize back ionization and are particularly suited for automatic guns where constant adjustments are impractical. As the air space between the gun and part decreases the resistance also decreases, therefore the current increases proportionately. With higher current, more and faster free-ions are generated. Higher current causes the part to reach saturation and back-ionization making it more difficult to build film and coat recess. These devices assist in reducing Faraday cage effects and help maintain optimum field strength and gun current between the electrode and parts.

Pauthenier's Equation

The ability of powder particles to develop a charge while passing through a corona field is governed by Pauthenier's equation.

$$q(t) = 4\pi \epsilon_0 \left(1 + 2 \frac{\epsilon_{r-1}}{\epsilon_{r+2}} \right) r^2 E \frac{enkt}{4 \epsilon_0 + enkt}$$

Where

r= Radius of particle

E= Field strength

e= Charge of an electron

k= Electron mobility

n= Electron concentration

t= Time

ϵ_0 = Absolute permittivity

ϵ_r = Relative permittivity of powder material

The amount of charge is directly proportional to the field strength geometry and the square of the particle radius. It is also affected by the particle and the amount of time in the charge zone.

Chapter Ten

Powder Application Tips

ALLEVIATING THE FARADAY CAGE

Overcoming the Obstacles of the Electrostatic Process

- Blast powder into the recesses
- Increase the powder flow rate
- Maximize the gun to part distance
- Use slotted tip to concentrate the spray

Trying to overcome the process leads to excess film thickness and powder usage and may cause a non-uniform build.

Using the Electrostatic Process

- Finesse the powder into recesses
- Decrease powder gun flow rates
- Reduce the gun's microamps (μA) to 20
- Maintain gun to part distance of $\sim 8\text{-}10\text{'}$
- Use slotted tip to concentrate spray
- Approach recess at an obtuse angle

These methods may result, though, in a slower application time.

Spraying in the Faraday Cage

Spraying at the recesses of a part at an obtuse angle can help to apply the coating properly.

- It reduces air turbulence
- Allows deeper penetration
- Minimizes early back ionization
- Utilizes more lines of force

A-Lines of Force

The corona generated charge field and lines of force tend to create Faraday cage difficulties.

B-Particle Space Charge

Lowering the voltage and allowing space charge created by powder cloud to develop near the recess will help with penetration.

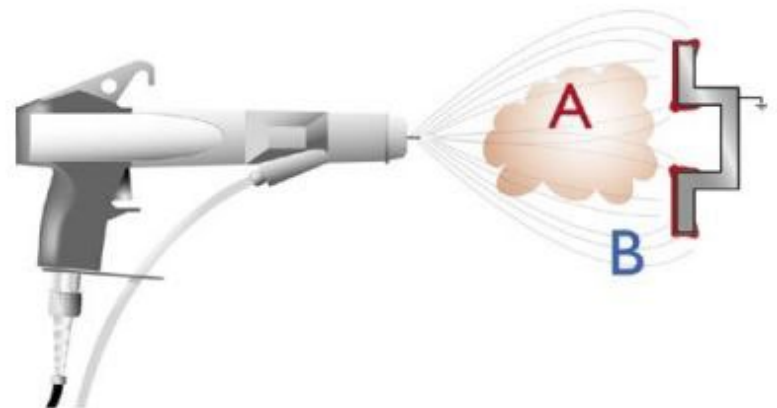
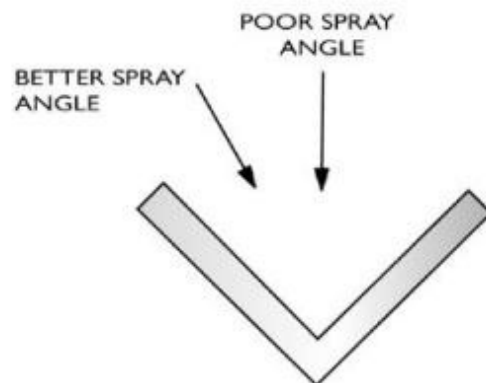
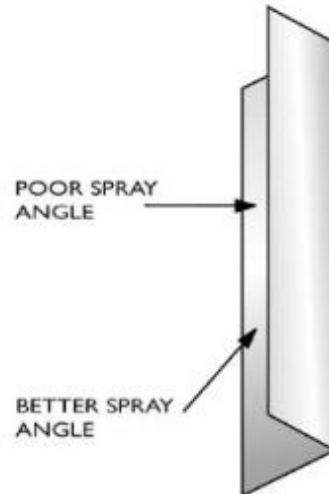

IMPACT FUSION

Impact fusion occurs when powder is subjected to high velocity and/or a restriction in its path. This creates excess friction, softening and depositing of powder at the point of contact.

Causes of Impact Fusion

- Plugged or worn pump sleeves
- Scratched or burred venturis
- Crimped, worn, or cracked hoses
- Deflectors and gun nozzles
- Powder pathway diameter change
- Heat present on powder pathway
- Excessively high gun pressures
- Low glass transition temperature powder
- Powder particle size too fine
- Moisture in the air supply

Impact Fusion on Hoses

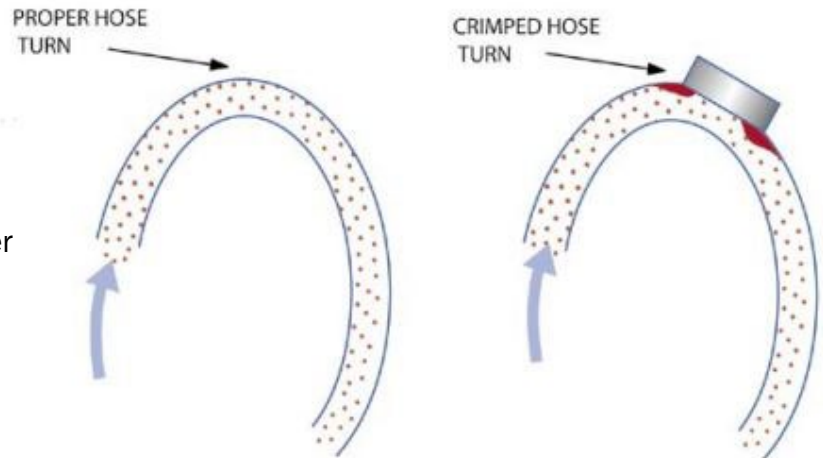

Venturi Impact Fusion

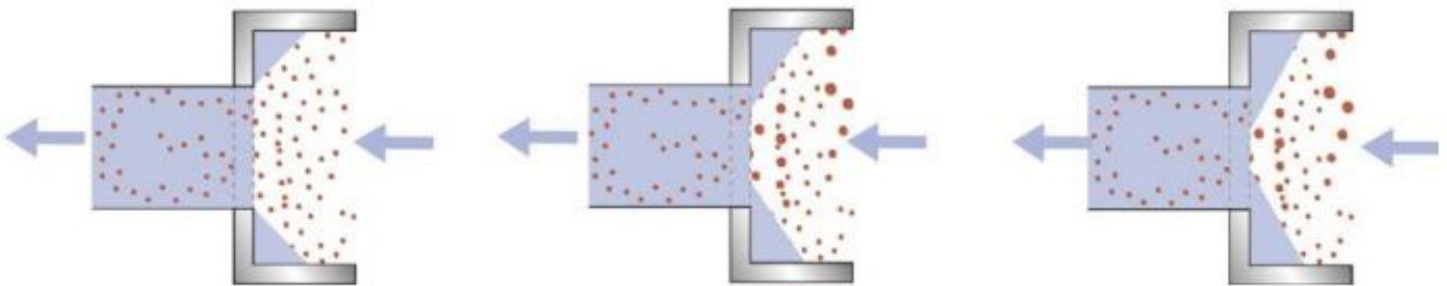

VENTURI AND GUN CONTROLS

Typically 2-3 Air Controls Per Gun

1. Powder Regulator (also called Flow or Main) controls the amount of powder being sprayed and the velocity and throw of the powder.
2. Atomizer Regulator (also called diffuser or Sub) controls the density and size of the powder cloud as well as insuring steady output.
3. Swirl Regulator (also called TIP) delivers air directly to the gun tip which can shape the cloud and prevent powder build up at the electrode and deflector.

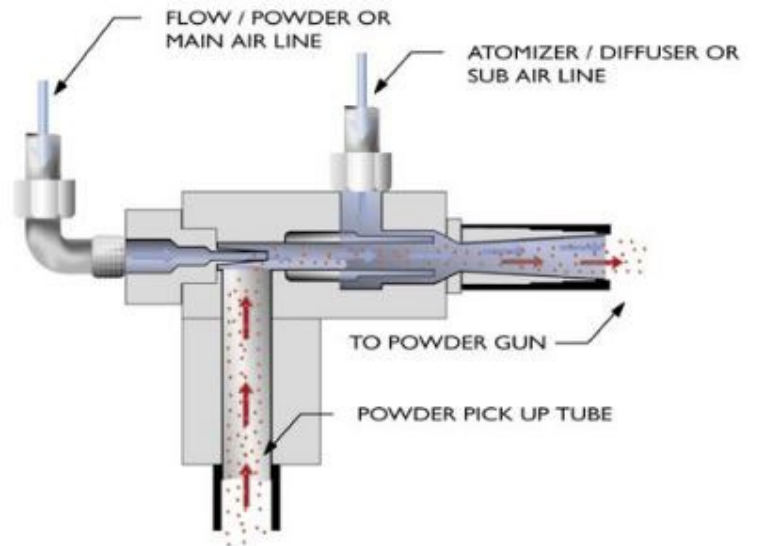

Fluidization pressure on a feed hopper can also noticeably affect the amount of powder being sprayed

POWDER, FLOW OR EJECTOR RATE



Too Low

- Powder spurting
- Low film Build
- Poor penetration into recesses

Too High

- High impact fusion
- High venturi wear
- Low transfer efficiency
- Low wrap
- Poor penetration into recesses

ATOMIZER OR DIFFUSER RATE



Too Low

- Powder spurting
- Streaking on parts
- Low wrap around

Too High

- Lower film build
- Lower transfer efficiency
- Fat edges
- Poor penetration into recesses

OPTIMIZING GUN PRESSURES

Excessive gun pressures will have a dramatic NEGATIVE impact on spray quality and efficiency.

Too much powder/flow pressure can:

- Cause excessive wear of equipment
- Create impact fusion problems
- Cause gun spitting and puffing
- Increase film thickness uniformity
- Decrease first pass transfer efficiency
- Increase amount of reclaim of overspray
- Reduce electrostatic attraction:
 - Large particles can bounce off
 - Particles traveling too fast for wrap
 - Less time in corona field charge
 - More particles to share charge
 - Increased friction generates high static (positive) charge and reduces the effectiveness of the corona (negative) charge



FACTORS AFFECTING CHARGE

- Composition
- Resin Type
- Resin Content- (% used in formula)
- Particle Size
- Particle Shape
- Substrate Type- (conductivity)
- Substrate Shape – (flat, frame, recess, etc.)
- Substrate Size
- Substrate Temperature
- Line Speed- (time to spray)
- Booth Air Flow
- Humidity
- Gun to Particle Distance
- Virgin to Reclaim Ratio
- Quality of Ground
- Gun Flow Rates- (volume to speed)
- Gun Tips & Deflectors
- Gun Voltage & Current- (amount of charge)



OPTIMIZING GUN TIPS

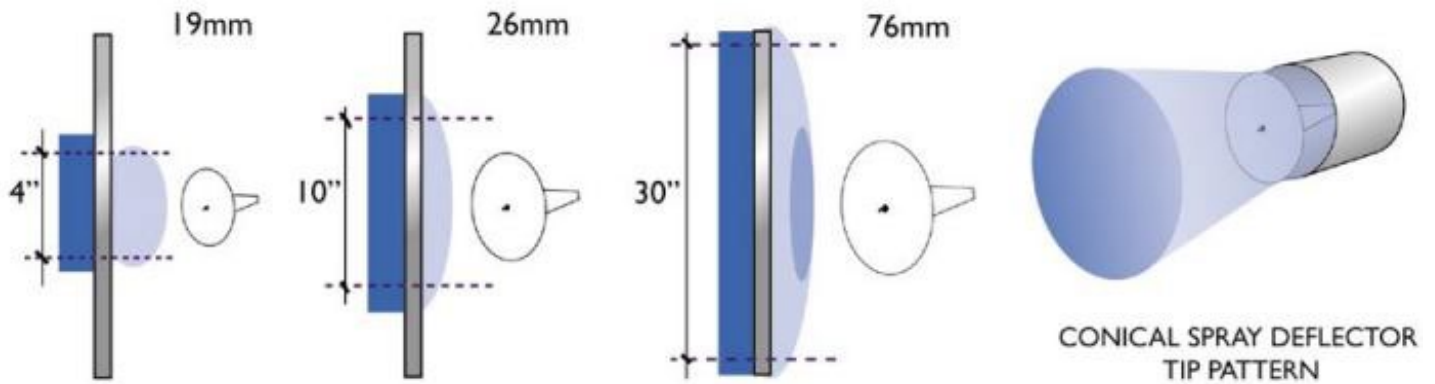

Deflector Size Effects on Powder Cloud

- Determines peak film build and uniformity
- Determines size and coverage area of cloud
- Concentrates powder along edges of patterns
- Gives more uniform deposit with moving parts

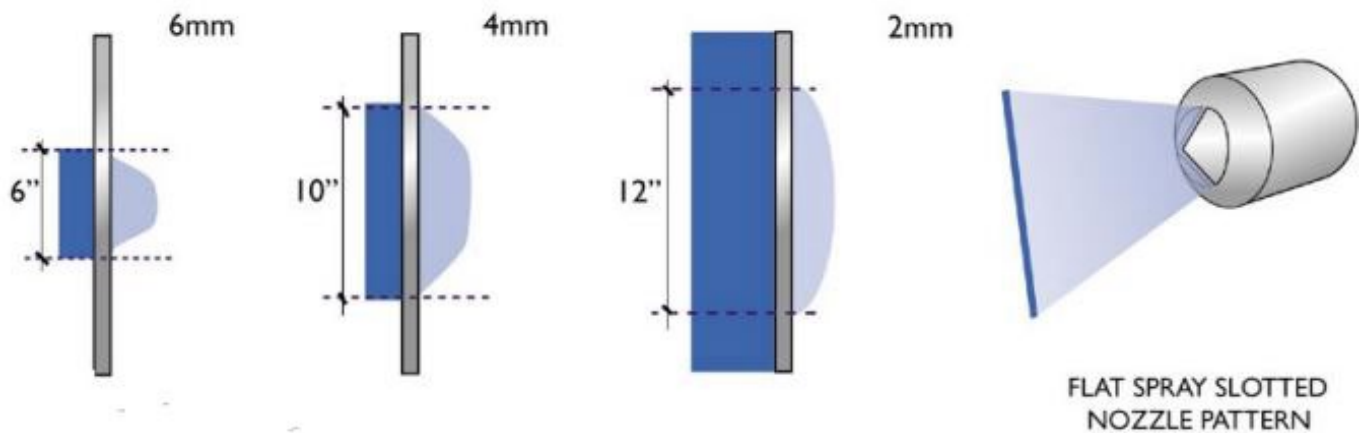

Nozzle Effects on Powder Cloud

- Develops flat rather than conical spray pattern
- Typically covers much smaller spray area
- Heavier build in center of spray pattern
- Concentrated more powder into recesses

APPLYING A SECOND COAT

Many obstacles associated with back-ionization are also encountered with a second coat of powder

- Cured film is a better dielectric insulator than powder
- Film has no way to bleed off free ions
- First coat gains charge rapidly

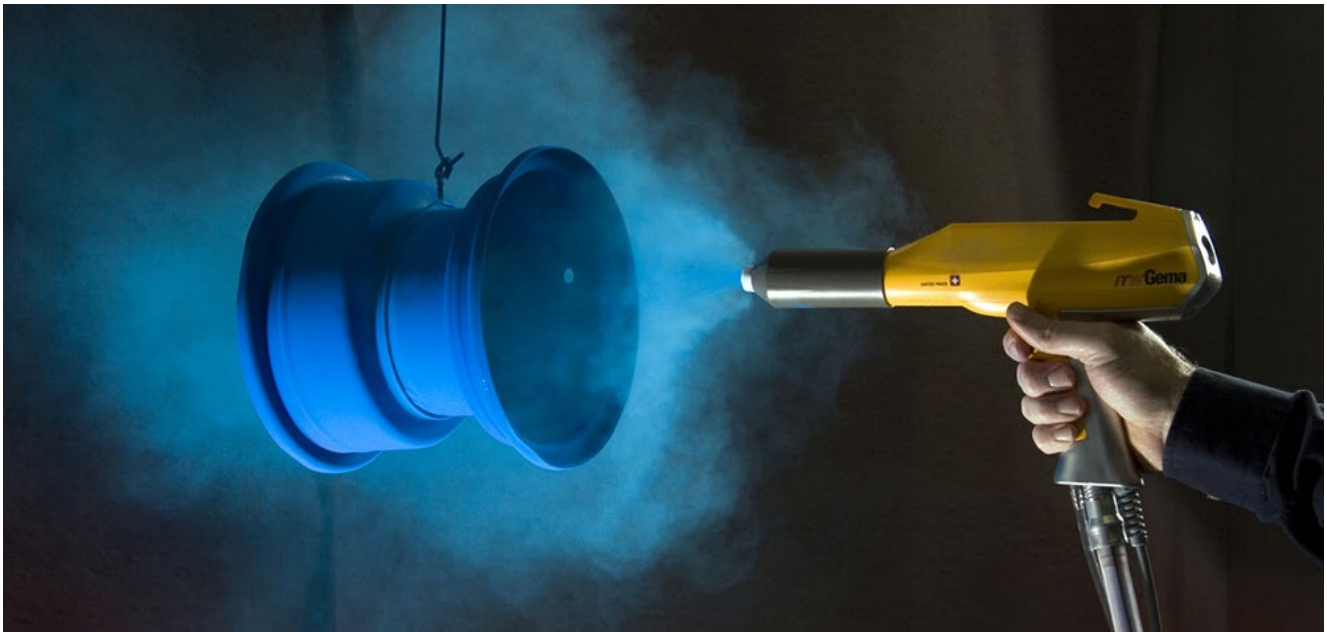

There are techniques to help in the application of a second coat

- Reduce microamps (μA) to 10
- Increase gun to part distance
- Slightly increase cloud density
- Use free ion collecting device

*To ensure good intercoat adhesion, it is also recommended that the coating be lightly sanded and then cleaned

Chapter Eleven

Powder Curing Process

BAKING NEEDS FOR POWDER COATINGS

Thermoplastic Powders

- Enough heat to liquefy and smooth out coating film

Thermoset Powders

- Sufficient heat to liquefy film
- Adequate time at the specified bake temperature to develop full design properties

Although the bake/cure process generally follows after the coating is applied there are instances when it's preferable to heat the substrate first.

- With cast iron/aluminum, preheating allows trapped gases to escape from the porous metal surfaces and reduces the tendency for the blisters to form in the film
- When the mass of the part is sufficient to allow residual heat to adequately cure it
- If higher than normal film thickness (greater than 6 mils) or fast film deposition is required

STAGES OF CURE DEVELOPMENT

Melt Point

- Powder particles begin changing from a solid to a semi-liquid state

Flow Stage

- Powder is fully liquefied, reaching lowest viscosity allowing film to smooth out

Cross Linking Stage

- Sufficient, sustained heat triggers large scale reaction within film, initial steps to total chemical/physical change of product

FACTORS AFFECTING CURE

- Powder chemistry
- Type of oven
- Metal thickness
- Temperature/voltage/wavelength
- Bake time
- Oven efficiency
- Air velocity



*Recommended cure times are based on time at METAL TEMPERATURE

Gel Stage

- When sufficient crosslinking has occurred, for solidification of the film from a liquid to a solid

Cure Development

- The final, and most critical stage when baking results in reaction of majority of crosslinking sites and development of full design properties

TYPICAL CURE DEVELOPMENT

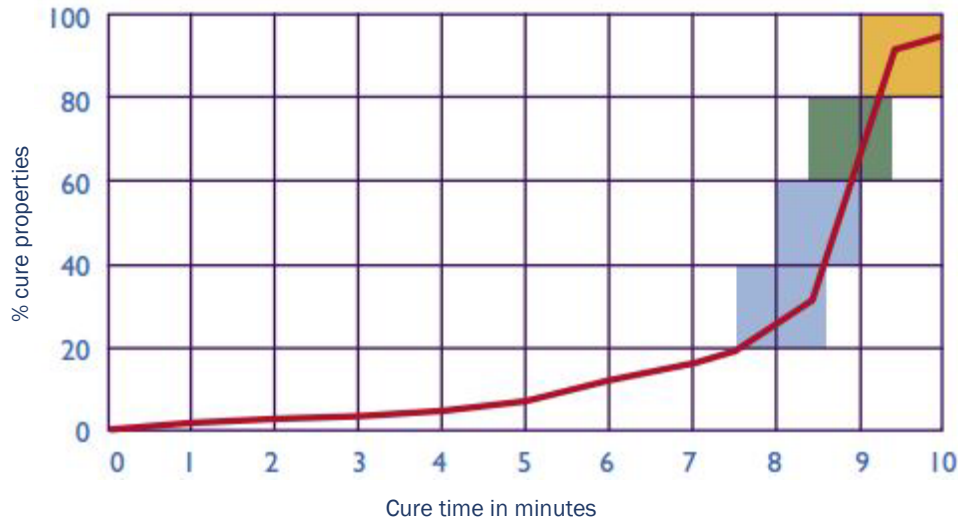

- Assume all cure times are at metal temperature
- 75% of properties develop in the last 15% of the cycle
- Various properties develop at different stages

Physical properties develop first
 Environmental properties next
 Chemical and full properties last

IMPORTANCE OF METAL THICKNESS

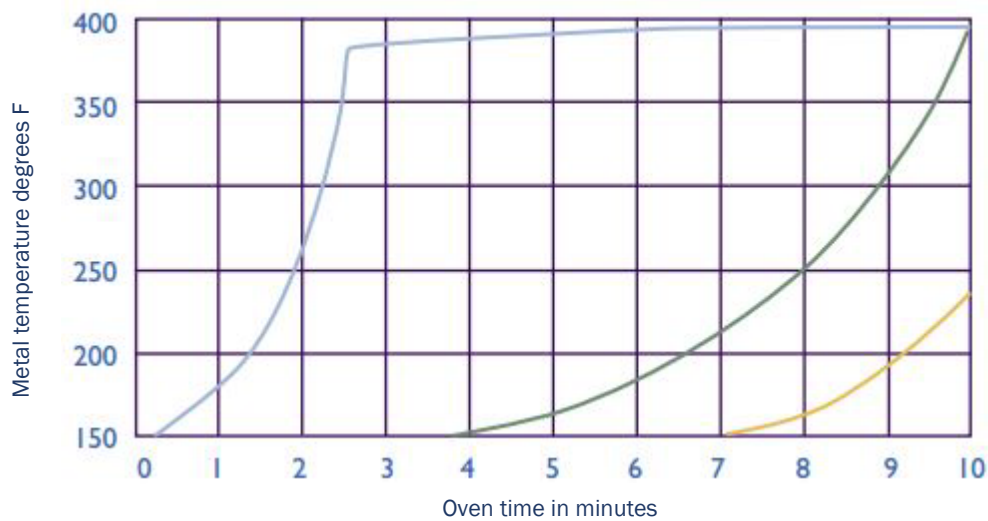

If cure requires a metal temperature of 10 minutes at 400°F. When is the start time?

1/16" thick sheet metal
 1/4" thick forged bracket
 3/4" thick cast iron yoke

BAKE OVEN DESIGNS AND ENERGY CONSUMPTION

- Convection
- Infrared
- Ultraviolet
- Electron Beam
- Induction

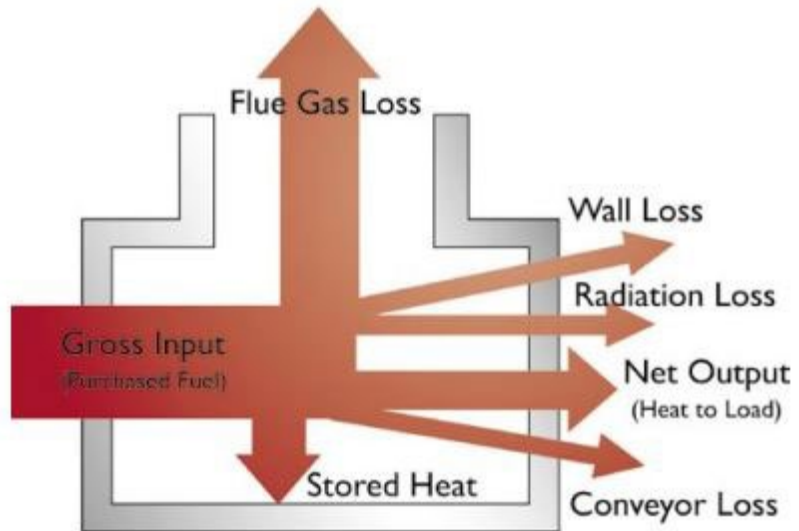

IR CURING SOURCES

- Reflected Energy- Energy that bounces back
- Absorbed Energy- Energy absorbed by the coating (usually by the pigment)
- Transmitted Energy- Energy that passes through the film where the substrate either absorbs or reflects the energy

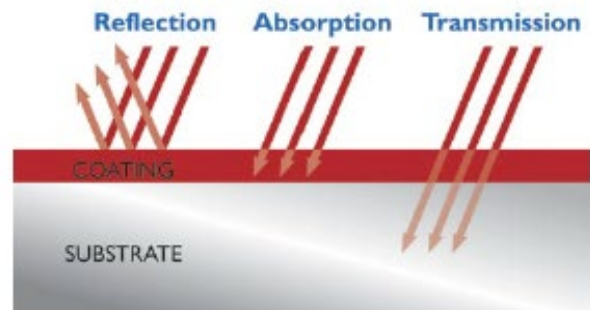

Different wavelengths have different curing properties to be considered

- Short Wave- 0.76 to 2.3 microns wave length with a source temperature of 2000 to 5000°F
- Medium Wave- 2.3 to 3.3 microns with a source temperature of 860 to 2000°F
- Long Wave- 3.3 to 1,000 microns with a source temperature of 100 to 860°F

*Organic coatings with C-H and O-H bonds have a peak absorption in the 2.2 to 3.3 micron wave length range

THE FREQUENCY SPECTRUM

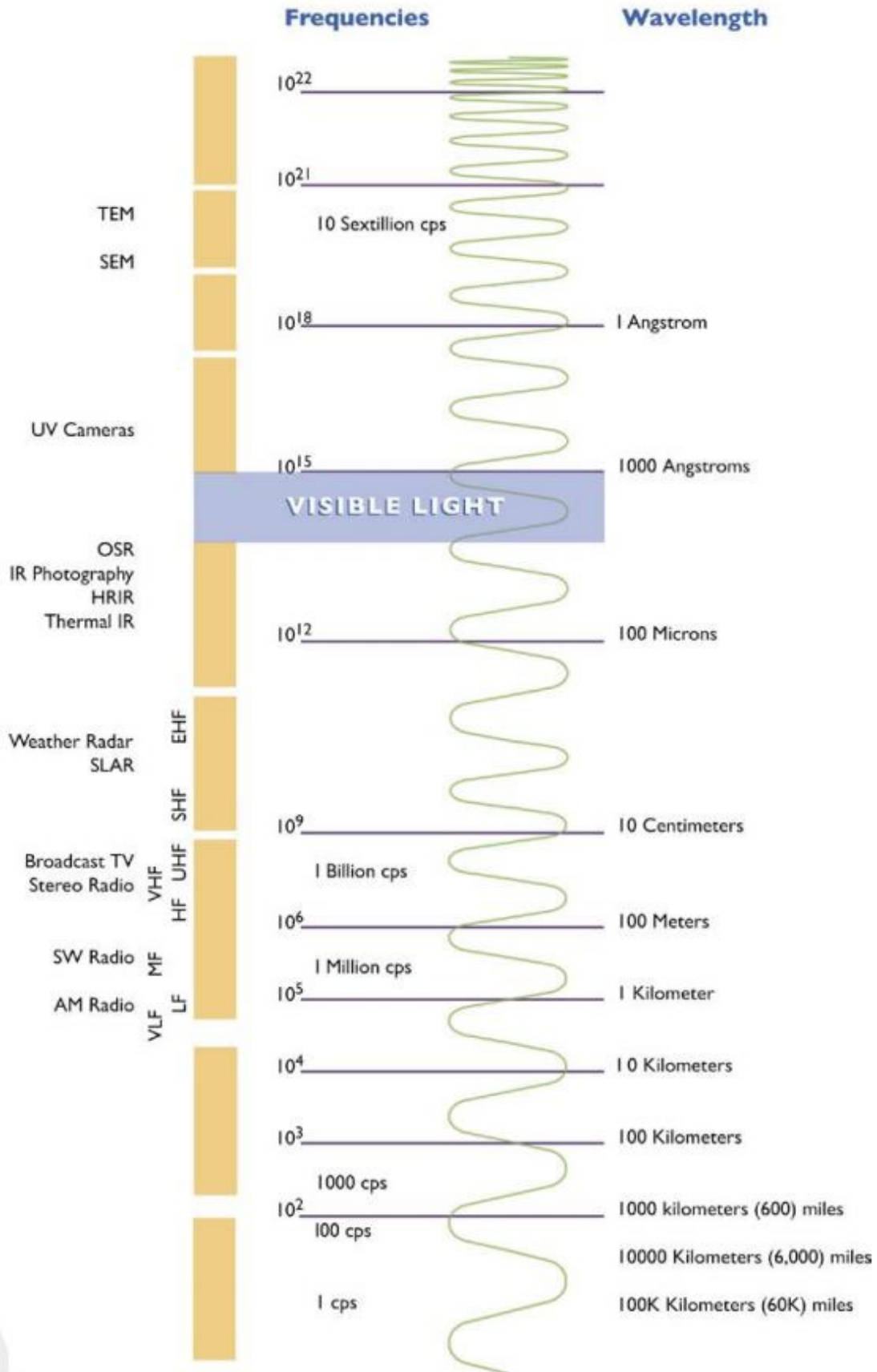

1 Angstrom = 10^{-8} centimeter; 1 Micron = 10^{-6} meters

RADIATION CHART

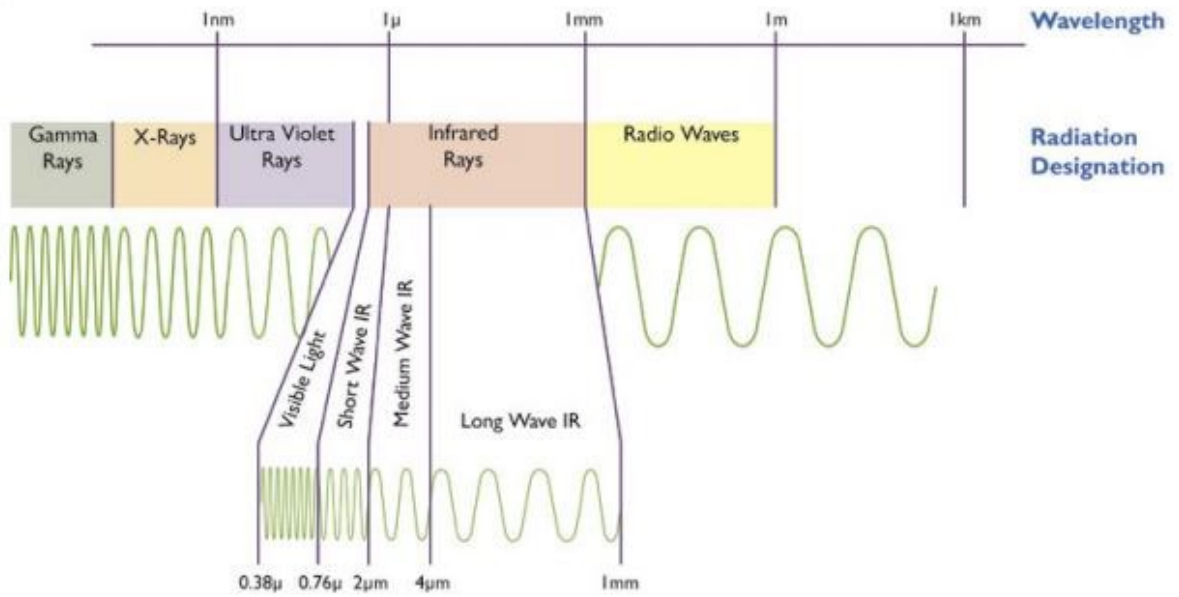

OPTIMUM INFRARED WAVE

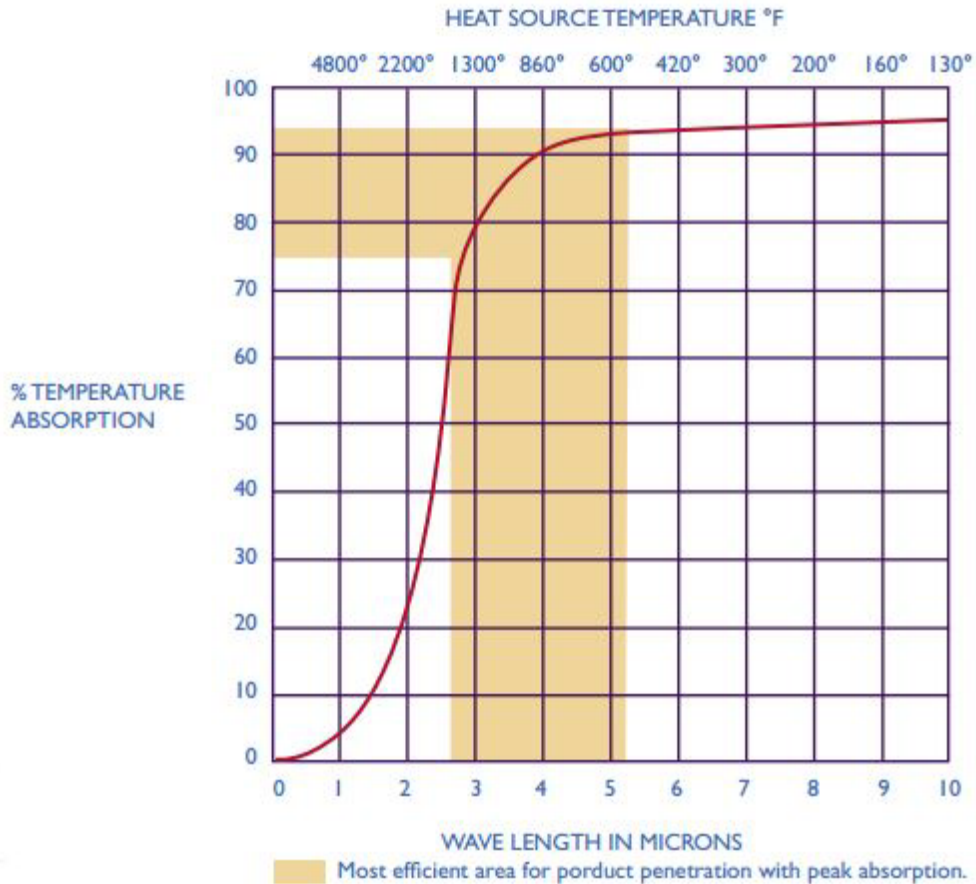

Chapter Twelve

Safety Issues with Powder Coatings

This manual is a guide to the technology of electrostatic coating operations. It is important that the equipment operators and supervisory personnel understand the requirements for safe operation. *This manual does not answer every circumstance. Each organization should examine their own coating operation, develop their own safety program and ensure that their workers follow correct procedures.*

***Be familiar with the safety requirements prescribed under the OSHA act of 1970 and in the NFPA bulletin #33**

HEALTH HAZARDS OF POWDER COATING

OSHA hazard communication standard CFR 29 1910.1200 requires chemical manufacturers to evaluate chemicals produced to determine if they are hazardous. Manufacturers review chemical substances to determine if they are carcinogenic, toxic, an irritant, dangerous to human organs, flammable, explosive, or reactive. This information is available to workers in the material safety data sheets (MSDS) that are supplied with materials. All powder coating materials are finely ground particulates. Such materials are classified by the American Conference of Governmental Industrial Hygienists (ACGIH) as particles not otherwise classified or (PNOC). PNOC's have a Threshold Limit Value (TLV) of occupational exposure of 10mg/m³, a level established for nuisance particulates.

RESPIRATORY PROTECTION

In operations where operators are working outside of the spray enclosure, a disposable dust mask is usually acceptable for respiratory protection. If the dust levels are higher than the TLV, half masks with cartridge filters can be used. For very high concentrations of powder or operations where operators are working inside the spray enclosure, full face masks with fresh air supply may be appropriate.

PERSONAL SAFETY

To limit the exposure to the eyes and skin, clothing and protective eye wear can be used to cover as much of the body as possible. Personnel grounding is the most difficult area of electrical hazard control. Most people do not realize what an excellent grounding source they are and that they can become a capacitor in a very short time. Manual operators are generally grounded through the spray gun itself as long as they hold it properly and the equipment is in proper working order. ITW Gema recommends that no glove be worn during the spray process. If gloves are worn during application, they should be specially designed for electrostatic application so that the operator is not isolated from ground. Powder should not be blown off of the skin with compressed air because it can force abrasive particles into the skin and eyes. Washing with soap and water is recommended for removal of powder from the skin. Good housekeeping should be practiced reducing accumulation of powder in the area and further reduce exposure.

SAFETY ISSUES CONTINUED

Handling of Powder Coatings

- Read the MSDS
- Avoid excessive skin exposure
- Wear proper respiratory equipment
- Wear proper clothing and eyewear

Fire Risk

- Maintain a safe concentration of powder in air outside the explosion (flammability) limits
- Eliminate any sources of ignition
- Maintain a good ground on everything in the powder coating system
- Maintain a good ground throughout the racks

Pretreatment Chemicals

- Read the MSDS
- Avoid skin contact
- Wear recommended safety clothing
- Maintain good ventilation

High Temperature Environments

- Limit access
- Never open washer or oven during operation
- Disconnect power before entering
- Use good lighting when entering
- Wear a hard hat in areas where it is necessary to stoop
- Know the hazards inside the equipment

For safe handling of materials and safe operation of equipment:

ALWAYS FOLLOW THE MANUFACTURERS WRITTEN PROCEDURES!



BASIC ELEMENTS OF COMBUSTION

Elements That Should Be Controlled or Eliminated

- Powder to air mixture- keep powder concentration outside the explosion (flammability) limits
- Compressed air supply
- Booth air flow
- Sparks from poor grounds
- Electrical equipment
- Matches
- Cigarettes

Controlling Powder to Air Mixtures

- Engineered powder systems
- Quality spray guns
- Exaggerated powder output
- Size of openings
- NFPA & OSHA exhaust guidelines
- System expansion factors
- Reduced efficiency factors

Heat/Ignition Source
(Sparks from poor grounds, electrical equipment, matches, cigarettes)

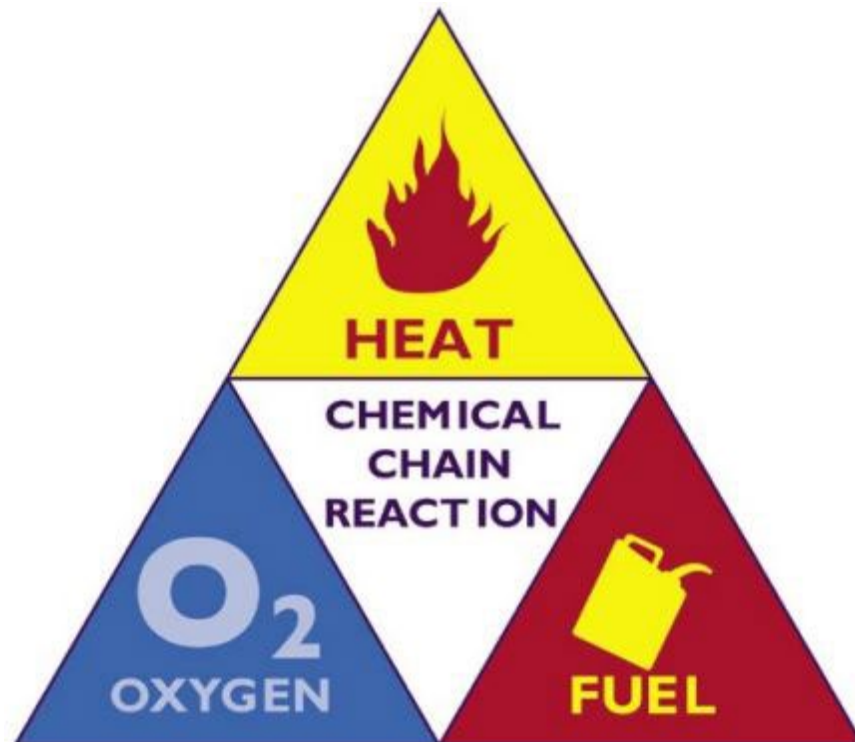

Oxygen
(Compressed air supply, booth air flow)

Fuel
(Powder to air mixture)

GROUNDING

Grounding an object means providing an adequate path for the flow of electrical charge from the object to ground. An adequate path is one that allows the charge to dissipate faster than charge is accepted to the part. NFPA 77 states the electrical resistance of such a leakage path may be as low as 1 Mega Ohm but the resistance can be as high as 10,000 Meg Ohms and still provide an adequate path in some cases. Powder coatings standards use one (1) Mega Ohm or less as a working ground to help ensure that proper discharge is achieved.

An ungrounded part will accept some voltage and attract some charged powder but at some point, will begin to repel the charged material. Examples of difficulties related to poor grounding are halos around hooks, inability to penetrate Faraday areas, and inconsistent or low film build. Larger parts will not show the effects of poor grounding as quickly as very small parts.

Poor grounding is a major safety issue. If the parts are isolated from ground, they can build up voltage to a point and then discharge to ground, creating an arc that has the potential to ignite the powder in the air-stream.

What is Good Ground?

Resistance greater than 1 Mega Ohm is considered to be loss of ground in the industry and is used by most equipment companies as a standard for their systems

How Is Ground Measured?

Ground is measured with an ohmmeter. One cable is attached to a known ground and one is attached to the rack contact or part. If there is resistance to conductivity greater than 1 Mega Ohm the system needs to be cleaned. Additional tests can tell precisely where the loss of ground is occurring; from house ground rod to the rail, the rail to the conveyor, conveyor to hanger attachment, hanger attachment to rack, or rack to part.

ONE MEGA OHM OR LESS IS THE ACCEPTED STANDARD IN THE POWDER COATING INDUSTRY

Chapter Thirteen

TCI Troubleshooting Guide

POWDER COATING APPEARANCE ISSUES

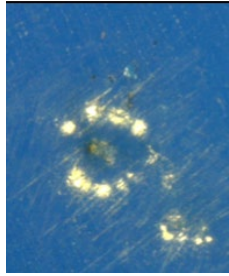



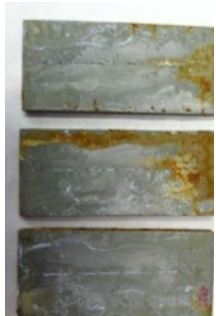

Problem	Potential Cause	Solution
Craters	Contaminates in compressed air	<i>Powder coating systems should have a dedicated regenerative air dryer. Compressed air should be at 38 °F dew point or lower. No particulates greater than 0.3 microns or oil greater than 0.1 ppm should be present.</i>
	Powder material incompatibility	<i>Make sure the powder coating system is cleaned properly</i>
	Air-born or foreign material incompatibility	<i>Inspect area for possible contaminants such as silicone</i>
	Insufficient substrate preparation	<i>Check pre-treat equipment and concentrations</i>
Pin-Holing	Contaminates in compressed air	<i>Check system for compressed air contaminants</i>
	Excessive Film Thickness	<i>Decrease film build via voltage, powder delivery, or lessen time sprayed on part</i>
	Excessive Oven Temperature	<i>Reduce oven temperature and/or time in oven</i>
	Substrate porosity	<i>Check the substrate for surface porosity. If substrate is sand-blasted, check recommended blast profile</i>
Color loss and poor opacity	Over-cured/ Under-cured	<i>Run DataPaq oven profiler to confirm proper cure. The recommended time at metal temperature should be met</i>
	Out-gassing and micro-pin holing	<i>Check for moisture within compressed air and check the surface for porosity</i>
	Contamination	<i>Make sure coating area is free from airborne contaminants and confirm powders are compatible.</i>
	Poor oven exhaust	<i>Check that the oven has the correct amount of turn-overs and that the oven exhaust are working properly</i>
Poor flow or too much orange peel	Film thickness too low (poor flow)	<i>Increase film thickness via voltage or higher powder delivery</i>
	Film thickness too high (orange peel)	<i>Surface overcharged Back Ionization</i>
	Powder too fine	<i>Adjust virgin/reclaim ratio</i>
	Oven temperature too high	<i>Adjust temperature/time</i>
	Coating not cured	<i>Adjust temperature/time</i>
Sagging	Film thickness too high	<i>Decrease film thickness via voltage or lower powder delivery</i>
	Too much powder sprayed on hot parts	<i>Hot parts attract more powder, apply correct film build</i>
	Oven temperature too low	<i>Increase oven temperature and/or time</i>
	Too much flow in powder	<i>Contact TCI</i>

CURED FILM PROPERTIES



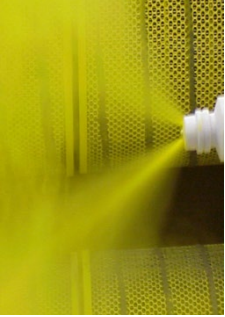

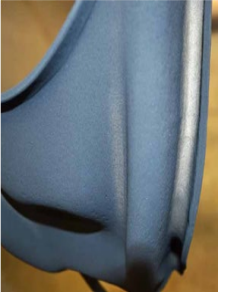

Problem	Potential Cause	Solution
Poor adhesion	Coating under-cured	<i>Run DataPaq oven profiler to confirm proper cure. The recommended time at metal temperature should be met</i>
	Insufficient substrate preparation	<i>Check pre-treat equipment and concentrations. Contact pretreat supplier</i>
	Excessive film thickness (creates brittleness)	<i>Decrease film build via voltage, powder delivery, or lessen time sprayed on part</i>
Poor impact resistance and flexibility	Excessive film thickness	<i>Decrease film build via voltage, powder delivery, or lessen time sprayed on part</i>
	Insufficient prep	<i>Check pre-treat equipment and concentrations</i>
	Coating under-cured	<i>Run DataPaq oven profiler to confirm proper cure. The recommended time at metal temperature should be met</i>
Poor pencil hardness and abrasion resistance	Coating under-cured	<i>Run DataPaq oven profiler to confirm proper cure. The recommended time at metal temperature should be met. Contact TCI representative</i>
Poor corrosion resistance	Insufficient substrate preparation	<i>Check pre-treat equipment and concentrations</i>
	Coating under-cured	<i>Run DataPaq oven profiler to confirm proper cure. The recommended time at metal temperature should be met</i>



APPLICATION

Problem	Potential Cause	Solution
 <p>Inconsistent powder delivery (guns are spitting and/or surging)</p>	Blockage in spray gun, powder feed hose, or pump	<ol style="list-style-type: none"> 1. Purge the spray gun. Remove the nozzle and electrode assembly and clean them. 2. Disconnect the powder feed hose from the spray gun and blow out the powder tube with an air gun. 3. Disconnect the powder feed hose from the pump and gun and blow out hose with an air gun. 4. Disassemble and clean the pump, replace venturi is worn.
	Damp powder	Check the powder supply, air filters, and air-dryer for moisture.
	Low pump air flow/pressure	Adjust pump air flow/pressure.
	Powder too fine	Adjust virgin/reclaim ratio.
	Poor powder fluidization	See "Hopper fluidization" section.
 <p>Powder repelling from parts (back ionization)</p>	Voltage too high	Adjust voltage on controller, activate current limiting.
	Excessive film build	Apply the powder to powder vendor's recommended film build.
	Poor Ground	Check the conveyor chain, load bars, and drop-down hooks for powder build-up. The resistance between the parts and ground must be 1 Meg-Ohm or less.
 <p>Insufficient powder coverage (poor penetration in faradays)</p>	Voltage too low or too high	Adjust voltage so coverage is even on edges and Faradays
	Powder/air velocity too high	Adjust air so the powder does not rebound from Faradays
	Poor Ground	Make sure part ground is below 1 Mega Ohm
	Powder application technique or improper gun placement	Make sure spray technique and patterns are directed properly
	Powder too fine	Adjust virgin/reclaim ratio.
 <p>Poor powder charging (poor wrap and film build)</p>	Poor voltage at gun tip	Measure voltage at gun tip with a kV analyzer. If results are poor, replace electrode and test again. Replace gun/multiplier as needed.
	Poor ground	Make sure part ground is below 1 Mega Ohm
	Powder too fine	Adjust virgin/reclaim ratio
	Humidity too low	Make sure paint room has a relative humidity in the 40% - 60% range

HOSES AND PUMPS

Problem	Potential Cause	Solution
 <p>Pumps and hoses clogged from impact fusion</p>	Build-up from routine maintenance not being performed	Clean and replace parts as needed. Start scheduled preventative maintenance
	Moisture in air supply	Make sure that air compressor and air drier are working properly
	Air pressures too high	Use lower air pressures on guns and powder transfer
	Powder too fine	Adjust virgin/reclaim ratio. Contact your local TCI service representative
   <p>Insufficient powder feed to application gun</p>	Poor powder fluidization	See "Hopper fluidization" section.
		Check and clean the pumps, pick-up tubes, and powder delivery hoses.
	Obstruction in powder delivery hose	Make sure that the sieve screen is working properly and that no holes or tears are present.
		Make sure that the powder is not clump inside the hopper and that no foreign materials are present.
	Powder delivery hoses kinked or crushed	Avoid sharp bends in powder hoses. Make sure hose length is not crushed under wheels, hoppers, or other equipment.
	Worn pump venturis	Check and rotate venturis daily. Replace all venturis out of range and clean impact fusion with non-metallic tools. Use an ultra-sonic cleaner for best results.
	Low air pressures	Check air delivery lines for kinks and/or obstructions. If none are found, slowly increase air supply to the feed pump.

FLUIDIZED HOPPERS

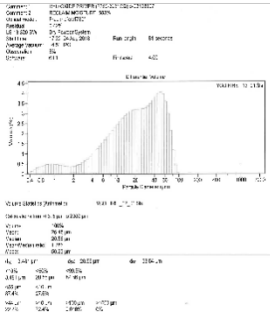
Problem	Potential Cause	Solution
 <p>Powder escaping from feed hoppers</p>	Excessive fluidizing pressure	Adjust fluidizing pressure so fluidized state is at a gentle roll.
	Poor hopper ventilation	Make sure that the hopper vent has a straight path and is not clogged. Adjust assist air accordingly
	Powder too fine	Use lower air pressures on guns and powder transfer
	Powder too fine	Adjust virgin/reclaim ratio.
 <p>Poor Fluidization</p>	Low air setting or improper air line size	Adjust air to properly fluidize. Make sure air line supply is of adequate size.
	Moist or clumpy powder in hopper	Feel bottom of hopper and make sure powder clumps are not present. If clumps are present contact powder supplier. Check air lines for moisture
	Fluidizing plate bad	Replace the fluidizing plate
 <p>Uneven deposition of fine and course powder particles inside the hopper</p>	Virgin/reclaim mix poor	Adjust virgin/reclaim ratio. Anything under 20% fines should work reasonably well. Above 20% fines may cause issues. If powder reaches above 25% fines, the feed hopper should be run down and reloaded with virgin. Contact your local TCI Service Representative to assist in balancing virgin/reclaim ratios.

Glossary of Industry Related Terms

ABRASION RESISTANCE: The resistance of a cured coating to physical damage from scratching, abrasives in cleaners or rubbing by contact with a hard object.

ACHROMATIC COLOR: A neutral color with no hue.

ATTRIBUTE: A distinguishing characteristic of appearance.

BACK IONIZATION, ELECTROSTATIC REJECTION OR

REPELLING: During electrostatic application, and excessive buildup of charged powder coating particles may limit further disposition of particles onto the substrate surface through reversal of the surface charge of the previously deposited particles.

BULK DENSITY: The mass required to occupy a specific unit of volume.

CHANNELING: Holes formed in the surface of the bulk powder as it is being withdrawn from below in the hopper.

CHEMICAL RESISTANCE: Tendency of a film to resist degradation upon exposure to various chemicals.

CHROMATIC: Color perception other than white, black or grey.

CHROMATICITY: Two-dimensional color specification, not involving illuminance, illustrated by pairs of numbers for dominant wavelength reflectance and purity.

CIE: International Commission on Illumination (Commission Internationale de L'Eclairage)

CIE CHROMATICITY COORDINATES (X, Y, Z) The ratio of each tristimulus value of a color to the summation of the tristimulus values.

CIE LUMINOSITY FUNCTION (Y) A plot of the magnitude of the visual response as function of the visible light wavelength.

CIE L*A*B UNIFORM COLOR SPACE Small color differences are measured by the Adams-Nickerson cube root formula.

CIE L*U*V UNIFORM COLOR SPACE Associated chromaticity is measured through additive mixing of light.

CIE STANDARD OBSERVER A field of vision, typically 2 or 10, containing hypothetical tristimulus color-mixture data.

CIE TRISTIMULUS VALUES Amount of the tristimulus values required to match a perceived color in a trichromatic system.

COLOR ATTRIBUTE: Color of an object defined in terms of lightness and chromaticity.

COLOR DIFFERENCE: The difference in lightness and chromaticity of two colors measured under the same conditions.

COLORIMETER: An instrument which measures color.

COLOR MEASUREMENT SCALE: A numerical system defining the perceived attributes of color.

COLOR SPECIFICATION: Numerical values of tristimulus, chromaticity, luminance, etc., defining a color within a particular color system.

COMPATIBILITY: The ability of two or more powder coating powders to be combined and applied to a substrate yielding no measurable difference in physical appearance and properties upon cure.

CORONA- CHARGING: Induction of a static charge on powder coating particles by passing the particle through an electrostatic field created by a high voltage device.

CROSS HATCH ADHESION: Adhesion of a cured film to a substrate is tested by scribing lines to produce 1/8 inch squares followed by the application of a specified pressure sensitive adhesive tape. After removing the tape any coating lifted off or other damage to the squares is analyzed. Reference ASTM D-3359

CURE END POINT: The moment at which a powder coating film has developed its specified properties.

CURE SCHEDULE: The temperature and dwell time required for a powder coating to achieve cure end point.

CUT THROUGH RESISTANCE: The ability of a curing powder coating film to resist penetration during application of a sharp edge, heat and pressure.

DELIVERY: The system for which a powder coating is applied and cured.

DENSITY: The ability of a material to absorb light (the darker the color the higher the density).

DRY BLENDING: A process where materials are blended without the use of solvents or melt mixing.

EDGE COVERAGE: An attribute of melted powder coating to flow and build film thickness at substrate edges, corner and angles.

ELECTROSTATIC DEPOSITION: The application of a charged powder coating onto a substrate with the opposite charge.

ELECTROSTATIC FLUIDIZED BED: The application of charged powder coating onto a grounded substrate as the substrate moves through a charged fluidized bed of the coating.

FARADAY CAGE EFFECT: An influence of a substrate's geometry where a field is generated inhibiting electrostatic application of particle with insufficient mass to penetrate the field.

FLEXIBILITY: The ability of a cured film to bend with- out cracking or loss of adhesion to the substrate.

FLOCKING DISPOSITION: The application of a powder coating onto a substrate which has been heated above the melt point of the powder coating.

FLUIDIZED BED: Powder coating particles are suspended, within a receptacle, emanating from a continuous evolution of gas through the particles reducing bulk density.

FUSION: The tendency of powder coating particles to melt, flow and form a continuous film upon heating.

GEL TIME: The time required for a thermoset powder coating to melt and advance to a gelled state at a defined temperature.

HUE: An attribute of color perception where a substrate is considered to be red, orange, blue, green, etc.

HUMIDITY RESISTANCE: The ability of a coating to maintain specified properties after exposure to a pre-designated environment of temperature and humidity.

IMPACT FUSION: Tendency for finely divided particle to combine with other particles within powder coating application equipment.

IMPACT RESISTANCE: The ability of a coating to withstand rapid deformation. Also, the degree of draw a coating that has been applied to a metal can tolerate.

INTERCOAT ADHESION: Adhesion which occurs between coatings applied at different times.

LIGHTNESS: A perception which enables one to distinguish a light-colored object from a dark colored object.

MANDREL BEND: A test for rating flexibility and toughness consisting of either cylindrical or conical mandrel. Coated panels are manually bent over mandrels of varying radii until cracking is apparent.

MEK RESISTANCE: A chemical resistance test where a gauze soaked with a solvent, MEK (methyl ethyl ketone), then the saturated gauze is rubbed back and forth over two inches of the coating.

MELT MIXING: A process by which ingredients are mixed together in a molten state.

MELT VISCOCITY: The measure of the viscosity of a material or blend of materials at a specified temperature.

METAL PRETREATMENT: A process of substrate preparation consisting of surface cleaning, rinse, phosphatizing, seal rinse and dry. Pretreatment increases coating adhesion and resistance to salt spray and humidity.

METAMERIC: Colors formulated with different sets of pigments that match under one type of illumination yet do not match under a second type of illumination.

MICRON: Unit of length equal to one millionth of an inch.

NANOMETER: Unit of length equal to 10⁻⁹meters.

OVERBAKE STABILITY: The ability of a powder coating to withstand an extended bake schedule without the color and gloss deviating from the standard.

PARTICLE SIZE: A discrete unit of size of powder coating particles created during the milling process. As a rule, the smaller the particle size the greater the surface area.

PARTICLE SIZE DISTRIBUTION: Classification of particles of similar size based on the total population analyzed, i.e. 100%. Graphic or numerical representation relays the quantity of particles of similar size, the distribution.

PENCIL HARDNESS: Abrasion resistance properties of a film are tested by forces applied to a substrate by a lead pencil(s) of varying degrees of hardness, ASTM D-3363.

PERCENT GLOSS: The amount of angular selectivity of reflectance responsible for the reflected objects being seen on the coating surface.

LASMA DISPOSITION: Disposition of a powder coating, predominantly thermoplastic, where the powder is carried by a gas through a flame source, allowing disposition of molten powder onto the surface of the substrate,

PLATE FLOW, INCLINED PLATE FLOW, GLASS PLATE FLOW, AND PILL FLOW: The distance a molten powder coating composition will travel, due to gravity, prior to gelation.

POURABILITY: A characteristic of a dry powder to flow uniformly from a container at a constant rate.

RECLAIM: A method where applied, non-deposited powder is collected for reapplication through the delivery system.

RECOVERY: A process where non-deposited powder is removed from the air before recirculating powder through the system.

SALT SPRAY RESISTANCE: The ability of a coating to protect a substrate against corrosion.

SATURATION: An attribute of color perception which differentiates migration from the grey of the same lightness.

SINTERING: The tendency of a powder to agglomerate during storage.

SOIL: The organic or inorganic contaminants on the surface of a substrate.

SPECIFIC GRAVITY: The ratio of the density of a substance to the density of a reference substance, typically water.

STANDARD: A reference for comparative measurements of color and other physical attributes.

STORAGE STABILITY: The ability of a material to maintain specified properties during recommended storage conditions.

SURFACE APPEARANCE: The physical attributes which define the surface of a coating.

T-BEND TESTS: An evaluation of flexibility where a coated strip of metal is bent around itself in multiple bends of 180°; first bend - 0T, second - 1T, third bend - 2T, the fourth bend - 3T. Reference ASTM D-4145.

TABER ABRASION: Abrasion resistance properties of a film are tested by forces applied to a substrate by an abrasive wheel, ASTM D-4060.

THEORETICAL COVERAGE The surface area of a substrate which a specific quantity of powder coating material will coat, as a function of specific gravity and coating thickness.

THERMOPLASTIC: A polymer which repeatedly softens on exposure to heat and returns to its original condition when cooled to room temperature.

THERMOSET: A polymer which irreversibly sets upon exposure to heat.

TRANSFER EFFICIENCY: A ratio or percent of powder deposited onto a substrate compared to the total amount of powder directed at the substrate.

TRANSPORTABILITY: The ability of a powder to be transported through a system.

TRIBO CHARGE: A deposition method where a powder particle generates a static charge by friction as the particles are transferred through a nonconductive material.

TRISTIMULUS: Color values which indicate the amount of red, green or blue receptors.

VIRGIN POWDER: Powder which has not been applied through an application system.

VOLATILE CONTENT: Tendency of number of components of powder coatings to pass into the vapor state at given time and temperature conditions.

WRAP: An electrostatic application phenomenon where charged particles are directed and adhere to the substrate away from the application point.